

<b>DE</b>	Installationsbeispiel	<b>2</b>
<b>FR</b>	Exemple d'installation	<b>4</b>
<b>EN</b>	Installation example	<b>6</b>
<b>IT</b>	Esempio per l'installazione	<b>8</b>
<b>ES</b>	Ejemplo de instalación	<b>10</b>
<b>NL</b>	Installatievoorbeeld	<b>12</b>
<b>DK</b>	Installationseksempel	<b>14</b>
<b>PT</b>	Exemplo de instalação	<b>16</b>
<b>PL</b>	Przykład instalacji	<b>18</b>
<b>CS</b>	Příklad instalace	<b>20</b>
<b>SK</b>	Příklad inštalácie	<b>22</b>
<b>ZH</b>	安装实例	<b>24</b>
<b>RU</b>	Пример установки	<b>26</b>
<b>FI</b>	Asennusesimerkki	<b>28</b>
<b>SV</b>	Installationsexempel	<b>30</b>
<b>LT</b>	Įrengimo pavyzdžiai	<b>32</b>
<b>HR</b>	Primjer instalacije	<b>34</b>
<b>TR</b>	Kurulum örneği	<b>36</b>
<b>RO</b>	Exemplu de instalare	<b>38</b>
<b>EL</b>	Παράδειγμα εγκατάστασης	<b>40</b>
<b>SL</b>	Primer inštalacije	<b>42</b>
<b>ET</b>	Raigaldusnäide	<b>44</b>
<b>LV</b>	Uzstādīšanas piemērs	<b>46</b>
<b>SR</b>	Primer instalacije	<b>48</b>
<b>NO</b>	Installasjonseksempel	<b>50</b>
<b>BG</b>	Пример за инсталация	<b>52</b>
<b>SQ</b>	Shembull instalimi	<b>54</b>
<b>AR</b>	مثال للتثبيت	<b>56</b>
<b>HU</b>	Felszerelési példa	<b>58</b>

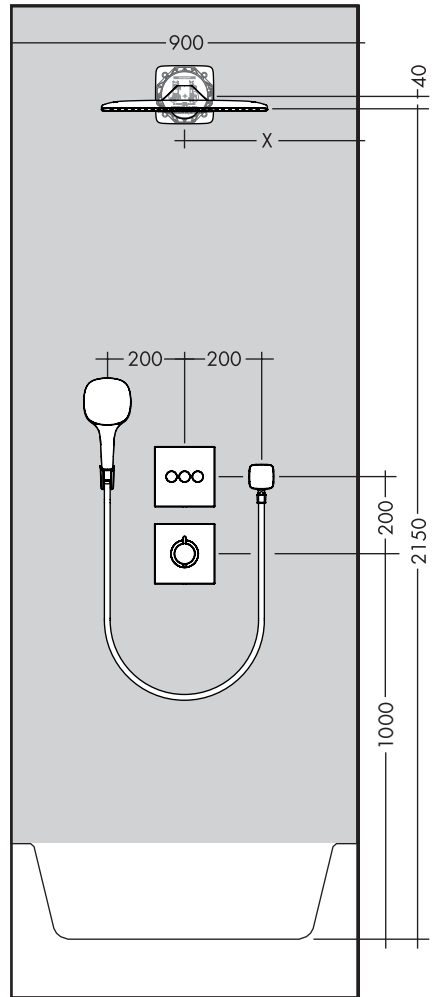



- Installationsbeispiele mit Maßangaben und Leitungsdimensionierung sind ab Seite 60 zu finden.
- Die in der Montageanleitung angegebenen Montagemaße sind ideal für Personen von ca. 1800 mm Körpergröße und müssen gegebenenfalls angepasst werden. Hierbei ist darauf zu achten, dass sich bei geänderter Montagehöhe die Mindesthöhe ändert und die Änderung der Anschlussmaße berücksichtigt werden müssen.
- Die Verbrauchswerte wurden praxisnah mit den dazugehörigen Armaturen (Thermostat/Mischer/Unterputzventil) gemessen.
- iBox in Kombination mit einer Exafill Wanneneinlauf mit Ab- und Überlaufgarnitur (siehe Seite 60)



iBox in Kombination mit einer Exafill Wanneneinlauf mit Ab- und Überlaufgarnitur

## Symbolerklärung

**X**

Mitte Badewanne / Mitte Duschwanne

**Y**

Maß Y = Mitte Schlauchanschlussbogen bis Mitte Wanneneinlauf dividiert durch 2 (eventuell dem Fliesenraster anpassen).



Warmwasser



Kaltwasser



Ab • ist die Funktion gewährleistet.



In diesem Bereich ist eine Wandverstärkung notwendig.



Nur ein Verbraucher möglich, nicht zwei gleichzeitig.



% Wasserleitungen für Seitenbrausen mit Gefälle verlegen.



Spülblock kpl. #15956000



Unterputz-Ventil



Quattro Vierwegeumstellung



Trio Universal Absperr- und Umstellventil



Wanneneinlauf



Der nicht benötigte Abgang muss mit einem Blindstopfen abgedichtet werden. (DN20, 3/4")



Die Ablaufleistung muss mehr als 50 l/min betragen.



Ablauf

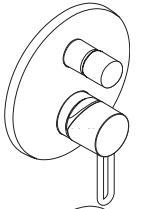

62, 72,  
74

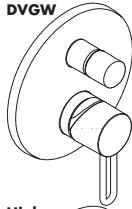

DVGW

60

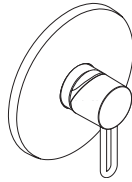

64 - 68,  
82

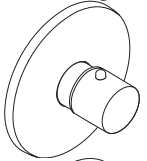

76, 80,  
84

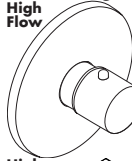

High Flow

86 - 90,  
94, 96,  
102 - 112

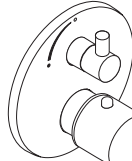

64 - 68,  
82

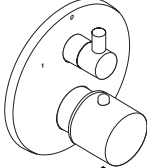

62, 72,  
74, 78

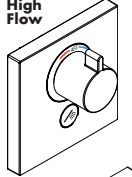

High Flow

92, 98,  
100, 114

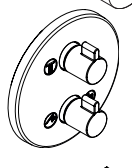

102

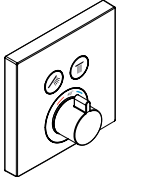

62, 72,  
74, 78

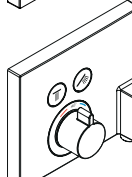

70

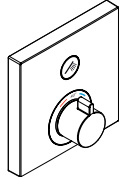

64 - 68

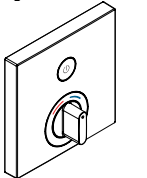

64 - 68

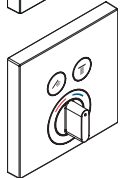

62, 72,  
74, 78

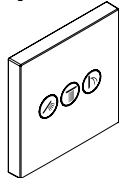

92,  
98 - 102,  
110 - 114

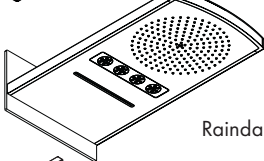

92, 94

Raindance Rainfall 240

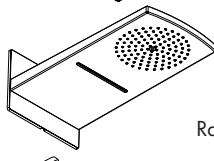

106 - 110

Raindance Rainfall 180

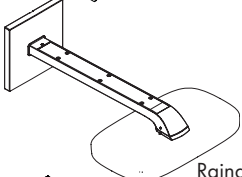

100

Raindance Select E 300

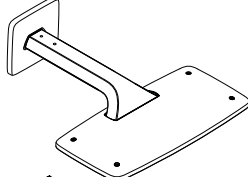

102, 104

Raindance E 420

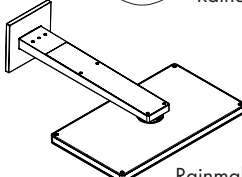

112

Rainmaker Select 460 2jet

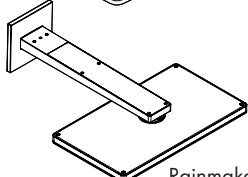

114

Rainmaker Select 460 3jet



- Des exemples d'installation avec indication de cotes et dimensions des conduites sont fournis à partir de la page 60.
- Les dimensions d'installation indiquées dans la notice de montage sont idéales pour des personnes d'une taille de 1800 mm environ et doivent être ajustées selon le cas. Tenir compte pour cela du fait qu'un changement de hauteur modifie la hauteur minimum et que la modification des cotes de raccord doit entrer en ligne de compte.
- Les valeurs de consommation ont été mesurées dans la pratique, avec les robinetteries correspondantes (thermostat/mélangeur/vanne sous crépi)
- iBox en combinaison avec un remplissage exafill avec mécanisme de vidage et de trop plein (voir pages 60)



## Vidage

iBox en combinaison avec un remplissage exafill avec mécanisme de vidage et de trop plein

## Description du symbole

**X** Centre de la baignoire / Centre cuvette de douche

**Y** Dimension Y = du centre raccord coudé de douche au centre bec déverseur divisé par 2 (éventuellement s'adapter au carrelage).



Eau chaude



Eau froide



A partir de • le fonctionnement est garanti.



Le mur n'a pas besoin d'être renforcé à cet endroit



Une seule utilisation possible, pas les deux ensemble.



% La tuyauterie des douchettes latérales à installer avec une pente.



bloc d'essai #15956000



Robinet d'arrêt encastré



Quattro inverseur quatre voies



Trio Robinet d'arrêt avec inverseur



Bec déverseur



La sortie non utilisée doit être condamnée avec un bouchon laiton. (DN20, 3/4")



Le débit de vidage doit être supérieur à 50 l/min.

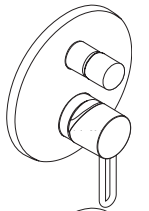

62, 72,  
74

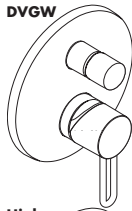

**DVGW**

60

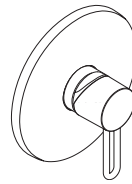

64 - 68,  
82

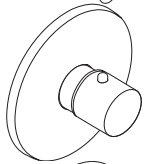

76, 80,  
84

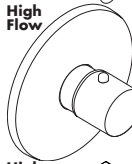

**High Flow**

86 - 90,  
94, 96,  
102 - 112

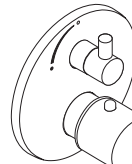

64 - 68,  
82

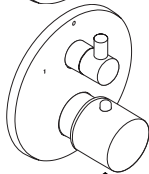

62, 72,  
74, 78

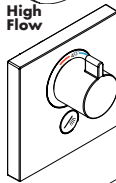

**High Flow**

92, 98,  
100, 114

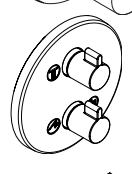

102

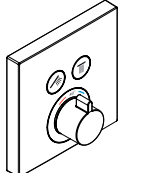

62, 72,  
74, 78

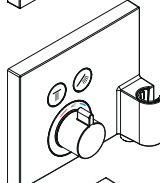

70

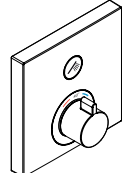

64 - 68

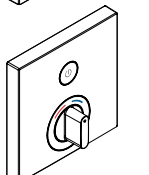

64 - 68

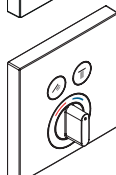

62, 72,  
74, 78

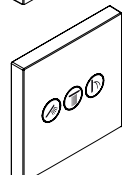

92,  
98 - 102,  
110 - 114

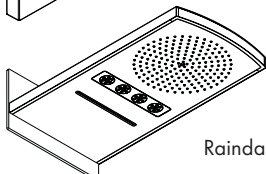

92, 94

Raindance Rainfall 240

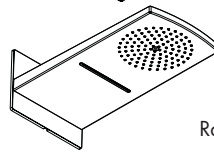

106 - 110

Raindance Rainfall 180

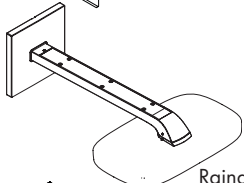

100

Raindance Select E 300

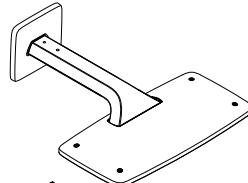

102, 104

Raindance E 420

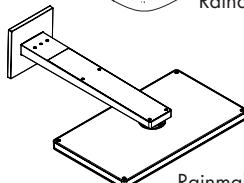

112

Rainmaker Select 460 2jet

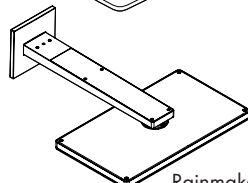

114

Rainmaker Select 460 3jet



- Installation examples with measurements and pipe dimensions can be found starting on page 60.
- The installation dimensions stated in these installation instructions are ideal for people of approximately 1800 mm in body height. The dimensions can be altered if required. In this case, pay attention to the fact that a change of installation height will also change the minimum height, and that the altered mounting dimensions must be taken into consideration.
- The consumption was measured in combination with the appropriate fittings (thermostat/mixer/in-wall valve) to reflect actual application in practice.
- iBox in combination with an Exafill bath filler with overflow and waste (see page 60)

## Symbol description



Center bath tub / Center shower tub



Dimension Y = center of hose wall outlet elbow to centre of bath filler divided by 2 (match to tile layout if applicable).



Warm water



Cold water



From • the function is guaranteed.



The wall must be reinforced in this area.



Only one function is possible.



% Install water pipes for body showers with a gradient.



flushing unit complete #15956000



Shut off valve



Quattro 4-Way Diverter Valve



Trio 2-Way Diverter Valve with integrated Shut-off valve



Bath Spout



Plug the unused outlet. (DN20, 3/4")



The waste drain performance must be more than 50 l/min.



Waste



iBox in combination with an Exafill bath filler with overflow and waste

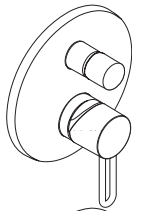

62, 72,  
74

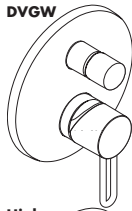

DVGW

60

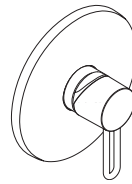

64 - 68,  
82

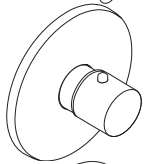

76, 80,  
84

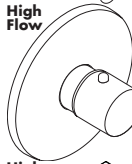

High  
Flow

86 - 90,  
94, 96,  
102 - 112

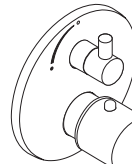

64 - 68,  
82

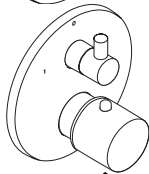

62, 72,  
74, 78

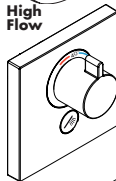

High  
Flow

92, 98,  
100, 114

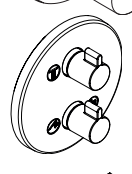

102

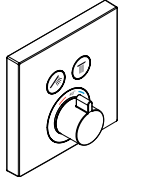

62, 72,  
74, 78

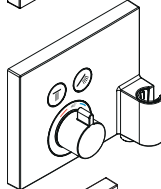

70

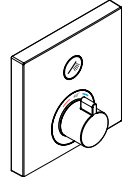

64 - 68

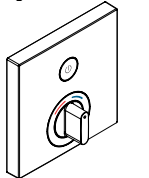

64 - 68

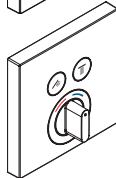

62, 72,  
74, 78

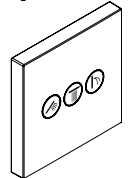

92,  
98 - 102,  
110 - 114

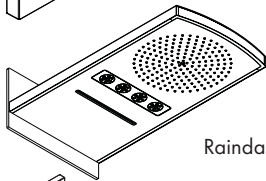

92, 94

Raindance Rainfall 240

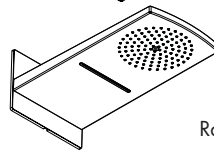

106 - 110

Raindance Rainfall 180

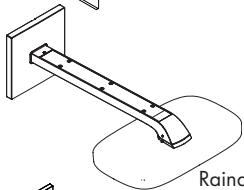

100

Raindance Select E 300

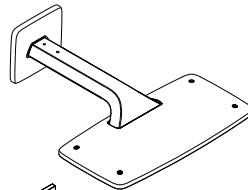

102, 104

Raindance E 420

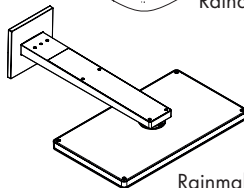

112

Rainmaker Select 460 2jet

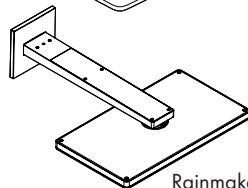

114

Rainmaker Select 460 3jet



iBox in combinazione con Exafill scarico con erogazione al troppo pieno

- Esempi per l'installazione con indicazioni delle misure e per le dimensioni delle tubature sono riportati a partire della pagina 60.
- Le quote di montaggio indicate nelle istruzioni di montaggio sono ideali per persone grandi circa 1800 mm e eventualmente vanno adattate. A ciò bisogna fare attenzione, che ad altezza di montaggio cambiata l'altezza minima necessaria indicata cambia e che bisogna considerare la modifica delle quote di collegamento.
- I valori di consumo sono stati misurati nella pratica con le armature appartenenti (Termostato/Miscelatore/Valvola sotto-intonaco).
- iBox in combinazione con Exafill scarico con erogazione al troppo pieno (vedi pagg. 60)

## Descrizione simbolo

**X**

Centro vasca / Centro piatto doccia

**Y**

Valore Y = Dal centro del raccordo a muro al centro della bocca di erogazione vasca diviso 2 (eventualmente adattare alla dimensione delle piastrelle).



Acqua calda



Acqua fredda



Dal • si garantisce la funzionalità.



In questa zona è necessario un rinforzo della parete.



Non è possibile utilizzare due utenze in contemporanea.



% Posizionare i tubi alle doccette laterali con una leggera pendenza.



placca frontale # 15956000



Rubinetto di arresto



Quattro Valvola a quattro vie



Trio arresto/deviatore



Bocca di erogazione



Chiudere con un tappo l'uscita non utilizzata. (DN20, 3/4")



La portata di scarico deve essere superiore a 50 l/min.



Scarico



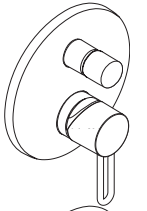

62, 72,  
74

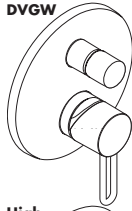

DVGW

60

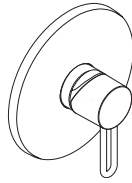

64 - 68,  
82

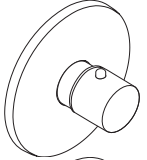

76, 80,  
84

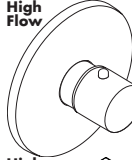

High  
Flow

86 - 90,  
94, 96,  
102 - 112

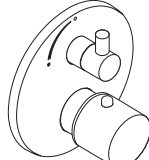

64 - 68,  
82

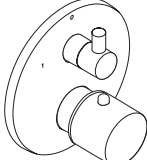

62, 72,  
74, 78

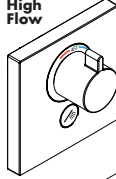

High  
Flow

92, 98,  
100, 114

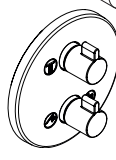

102

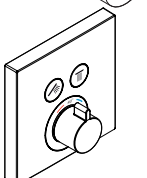

62, 72,  
74, 78

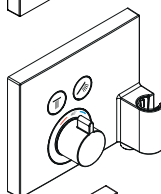

70

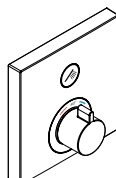

64 - 68

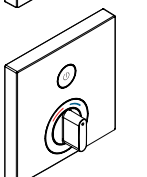

64 - 68

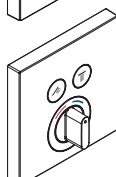

62, 72,  
74, 78

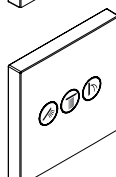

92,  
98 - 102,  
110 - 114

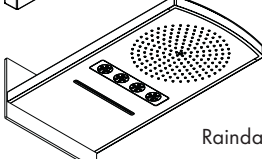

92, 94

Raindance Rainfall 240

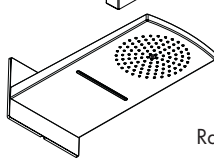

106 - 110

Raindance Rainfall 180

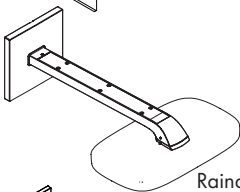

100

Raindance Select E 300

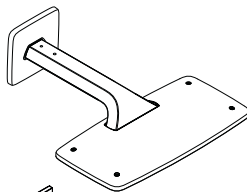

102, 104

Raindance E 420

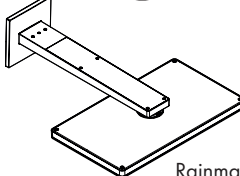

112

Rainmaker Select 460 2jet

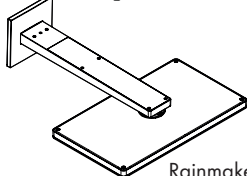

114

Rainmaker Select 460 3jet



- A partir de la página 60 puede consultar ejemplos de instalación y dimensionamiento de la conducción.
- Las medidas indicadas en las instrucciones de montaje resultan ideales para personas de 1800 mm de altura, por lo que deberán ajustarse siempre que sea necesario. En este sentido, es importante tener en cuenta que, en caso de modificación de la altura de montaje, cambia la altura mínima y habrá que adaptar las medidas de conexión.
- Los valores de consumo han sido medidos en la práctica con los grifos correspondientes (termostato/mezclador/válvula empotrada).
- iBox universal en combinación con Exafill, vaciador automático con chorro incorporado y rebosadero (ver página 60)



Desagüe

iBox universal en combinación con Exafill, vaciador automático con chorro incorporado y rebosadero

## Descripción de símbolos

**X** Centro de la bañera / Centro la plato de ducha

**Y** Medida Y = Desde el centro del racor de empalme hasta el centro de la boca de entrada a la bañera dividido por 2 (si fuera necesario, adaptar a la trama de los azulejos).

 Agua caliente

 Agua fría

 Mínimo • para el correcto funcionamiento.

 En este sector es necesario un refuerzo del muro.

 Sólo una función posible, no dos funciones al mismo tiempo.

 % Tubería hacia las duchas laterales con pendiente.

 Carcasa para purgar #15956000

 Llave de paso

 Quattro válvula de 4 vías

 Trio llave de paso y distribuidor

 Caño de bañera

 La salida que no se utiliza debe ser tapada. (DN20, 3/4")

 El caudal de desagüe debe ser como mínimo de 50 l/min

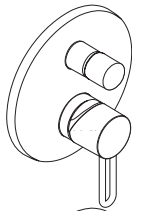

62, 72,  
74

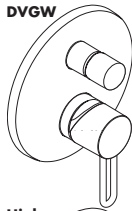

DVGW

60

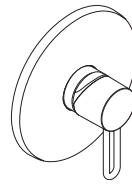

64 - 68,  
82

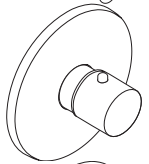

76, 80,  
84

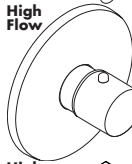

High  
Flow

86 - 90,  
94, 96,  
102 - 112

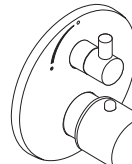

64 - 68,  
82

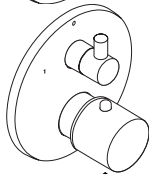

62, 72,  
74, 78

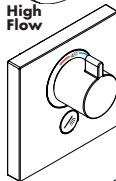

High  
Flow

92, 98,  
100, 114

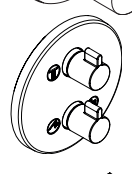

102

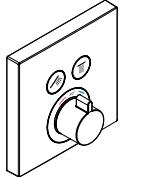

62, 72,  
74, 78

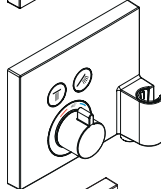

70

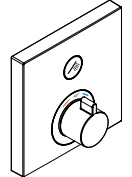

64 - 68

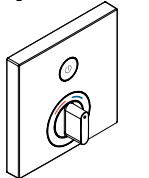

64 - 68

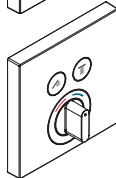

62, 72,  
74, 78

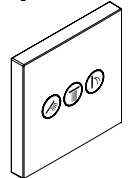

92,  
98 - 102,  
110 - 114

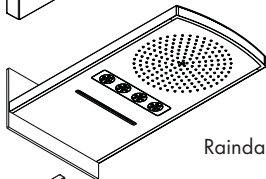

92, 94

Raindance Rainfall 240

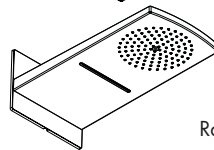

106 - 110

Raindance Rainfall 180

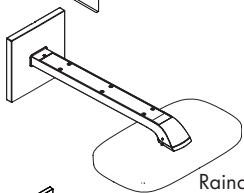

100

Raindance Select E 300

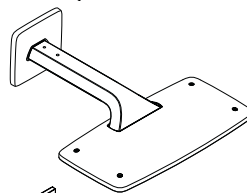

102, 104

Raindance E 420

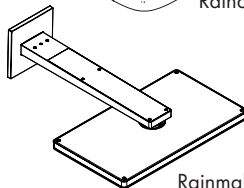

112

Rainmaker Select 460 2jet

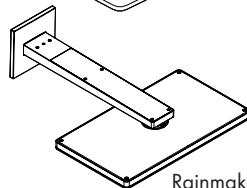

114

Rainmaker Select 460 3jet



- Installatievoorbeelden met massagegegevens en capaciteitsdimensionering staan op pagina 60.
- De in de handleiding aangegeven montagematen richten zich op personen van ca. 1800 mm groot en moeten indien nodig aangepast worden. Daarbij moet in acht genomen worden dat bij een gewijzigde montagehoogte ook de minimumhoogte verandert en dat de aansluitmaten overeenkomstig moeten worden aangepast.
- De verbruikswaarden werden in overeenstemming met de praktijk met de bijbehorende armaturen (thermostaat/mengkraan/inbouwventiel) gemeten.
- iBox in combinatie met Exafill badvul-, afvoer- en overloopgarnituur (zie blz. 60)



iBox in combinatie met Exafill badvul-, afvoer- en overloopgarnituur

## Symboolbeschrijving

**X**

Midden bad / Midden Douchebak

**Y**

Maat Y = afstand tussen muuraansluitbocht en baduitloop hart op hart, gedeeld door 2 (eventueel rekening houden met de wandtegels).



Warm water



Koud water



Vanaf • is het functioneren gegarandeerd.



In dit bereik is een wandversterking noodzakelijk.



Slechts 1 functie mogelijk: geen 2 functies tegelijkertijd.



% Waterleidingen voor zijdouches aflopend plaatsen.



spoelblok kompl. #15956000



Inbouwstopkraan



Quattro 4-weg omstelkraan



Trio stop- en omstelkraan



Baduitloop



De niet benodigde uitgang moet met een blindstop worden afgedicht. (DN20, 3/4")



De afvoercapaciteit moet meer dan 50 l/min bedragen.



Afvoer

Raindrain

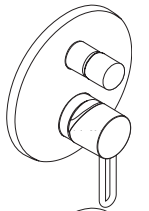

62, 72,  
74

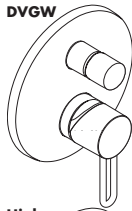

DVGW

60

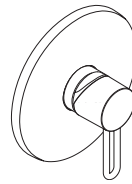

64 - 68,  
82

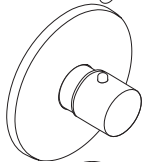

76, 80,  
84



High  
Flow

86 - 90,  
94, 96,  
102 - 112

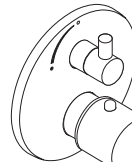

64 - 68,  
82

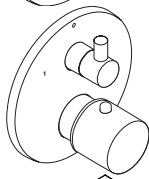

62, 72,  
74, 78

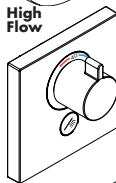

High  
Flow

92, 98,  
100, 114

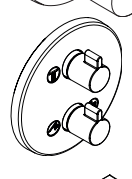

102

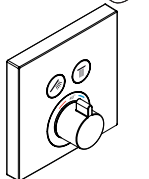

62, 72,  
74, 78

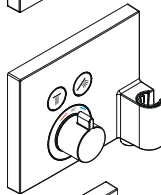

70

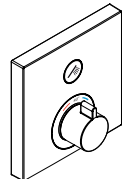

64 - 68

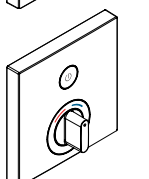

64 - 68

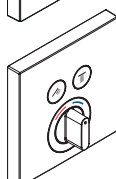

62, 72,  
74, 78

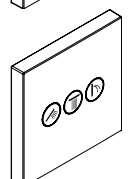

92,  
98 - 102,  
110 - 114

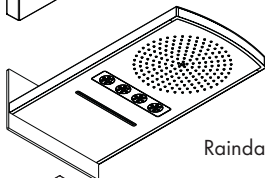

92, 94

Raindance Rainfall 240

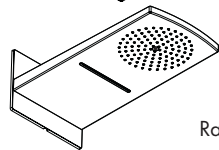

106 - 110

Raindance Rainfall 180

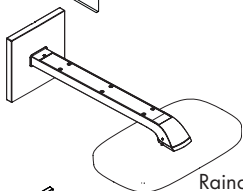

100

Raindance Select E 300

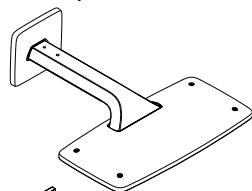

102, 104

Raindance E 420

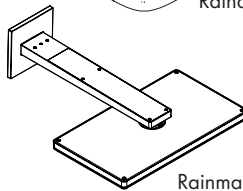

112

Rainmaker Select 460 2jet

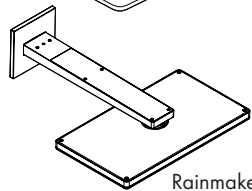

114

Rainmaker Select 460 3jet



- Installationseksempler med mål og ledningsdimensioner kan findes fra side 60.
- Målene i monteringsanvisningen er ideal til personer med en størrelse på 1800 mm og skal i givet fald tilpasses. Herved skal der tages hensyn til, at den mindste højde i tilfælde af en ændret monteringshøjde ændres og at der skal tages hensyn til de ændrede tilslutningsmål.
- Værdierne for forbruget blev målt praksisorienteret og med de tilsvarende armaturer (termostat/blender/indbygget ventil).
- iBox i kombination med Exafill påfyldnings- og overløbsgarniture (se s. 60)

## Symbolbeskrivelse

**X**

Midt badekar / Midt brusekar

**Y**

Mål Y = Midt slangeudtag til midt kartud divideret med 2 (evt. tilpas med fugerne i fliserne).



Varmt vand



Kold vand



Fra • er funktionen anvendelig.



I dette område er en forstærkning af væggen nødvendigt.



Det er kun muligt at benytte én funktion ad gangen.



% Vandledninger til sidebruserne med fald.



Skylleblok kpl. # 15956000



Afspæringsventil



Quattro 4-vejs ventil



Trio afspæringsventil og omskifter



Kartud



Afgangen, der ikke benyttes, skal afproppes. (DN20, 3/4")



> 50 l/min

Afløbskapaciteten skal være mere end 50 l/min.



Afløb



iBox i kombination med Exafill påfyldnings- og overløbsgarniture

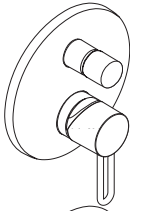

62, 72,  
74

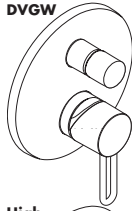

DVGW

60

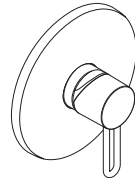

64 - 68,  
82

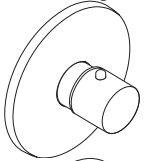

76, 80,  
84

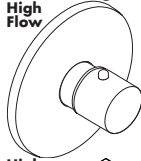

High  
Flow

86 - 90,  
94, 96,  
102 - 112

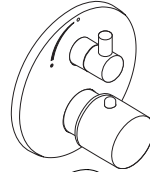

64 - 68,  
82

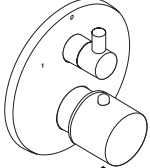

62, 72,  
74, 78

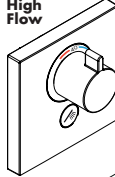

High  
Flow

92, 98,  
100, 114

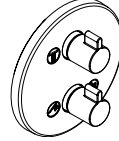

102

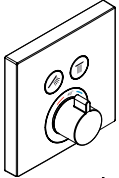

62, 72,  
74, 78

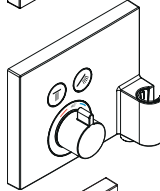

70

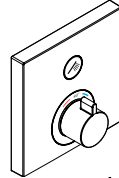

64 - 68

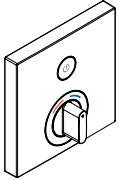

64 - 68

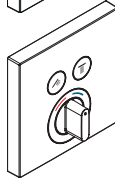

62, 72,  
74, 78

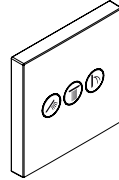

92,  
98 - 102,  
110 - 114

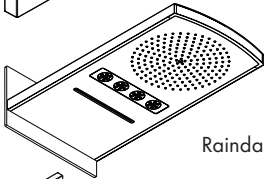

92, 94

Raindance Rainfall 240

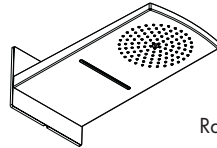

106 - 110

Raindance Rainfall 180

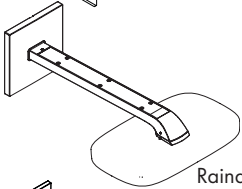

100

Raindance Select E 300

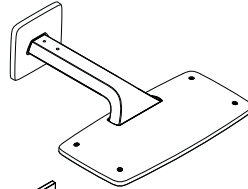

102, 104

Raindance E 420

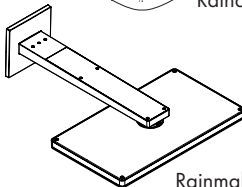

112

Rainmaker Select 460 2jet

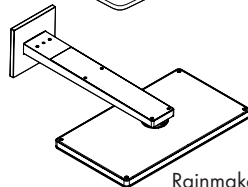

114

Rainmaker Select 460 3jet





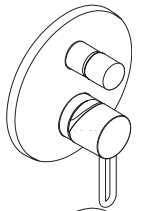

62, 72,  
74

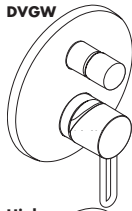

DVGW

60

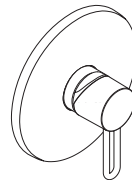

64 - 68,  
82

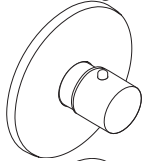

76, 80,  
84

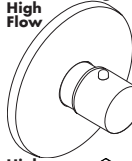

High  
Flow

86 - 90,  
94, 96,  
102 - 112

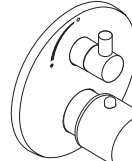

64 - 68,  
82

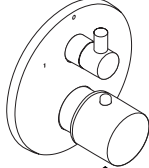

62, 72,  
74, 78

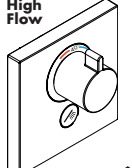

High  
Flow

92, 98,  
100, 114

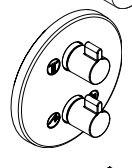

102

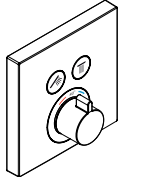

62, 72,  
74, 78

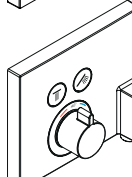

70

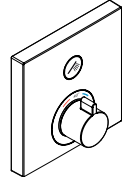

64 - 68

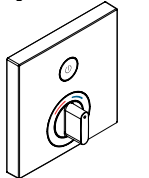

64 - 68

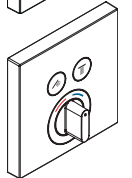

62, 72,  
74, 78

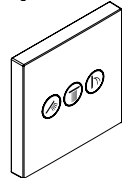

92,  
98 - 102,  
110 - 114

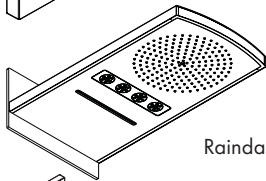

92, 94

Raindance Rainfall 240

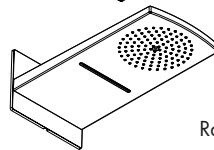

106 - 110

Raindance Rainfall 180

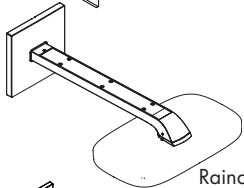

100

Raindance Select E 300

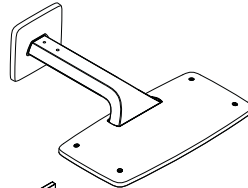

102, 104

Raindance E 420

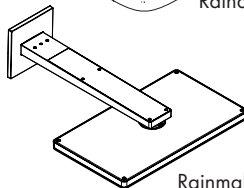

112

Rainmaker Select 460 2jet

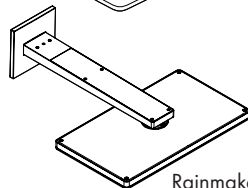

114

Rainmaker Select 460 3jet



iBox w kombinacji z odpływem wannowym Exafill posiadającym możliwość napełniania i opróżniania wanny

- Przykłady instalacji z podaniem ciężarów i rozmiarów przewodów, patrz od strony 60.
- Wymiary montażowe podane w instrukcji montażowej są idealne dla osób o wzroście sięgającym ok. 1800 mm i w razie konieczności należy je dostosować. Należy przy tym zwrócić uwagę na fakt, iż przy zmienionej wysokości montażu zmienia się minimalna wysokość, a także ulegają zmianie wymiary przyłączy.
- Wartości zużycia zostały zmierzone w praktyczny sposób za pomocą przynależnej armatury (termostat/mieszalnik/zawór podtynkowy).
- iBox w kombinacji z odpływem wannowym Exafill posiadającym możliwość napełniania i opróżniania wanny (patrz strona 60)

## Opis symbolu

**X**

Środek wanny / Środek brodzika

**Y**

Wymiar Y = środek mocowania węża prysznicowego do środka wylewki napełniającej wannę podzielony przez 2 (ewentualnie dopasować do układu płytek ceramicznych).



Ciepła woda



Zimna woda



Od • możliwe jest funkcjonowanie.



W tym obszarze konieczne jest wzmocnienie ściany.



Możliwe uruchamianie tylko każdego odbiornika osobno.



Przewody doprowadzające do pryszniców bocznych położyć z nachyleniem.



Blok płuczący #15956000



Zawór podtynkowy



Regulator czterodrożny Quattro



Zawór odcinający i regulacyjny Trio Universal



Wylewka wannowa



Niewykorzystany wylot należy zakorkować dołożonym w dostawie korkiem. (DN20, 3/4")



Wydajność odpływu musi być wyższa niż 50 l/min.



Odpływ

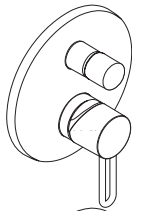

62, 72,  
74

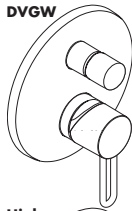

DVGW

60

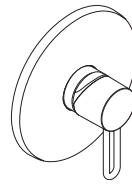

64 - 68,  
82

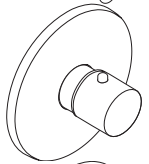

76, 80,  
84

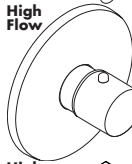

High  
Flow

86 - 90,  
94, 96,  
102 - 112

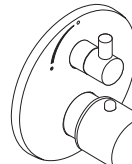

64 - 68,  
82

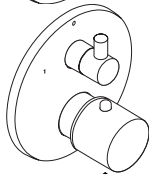

62, 72,  
74, 78

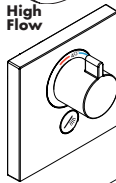

High  
Flow

92, 98,  
100, 114

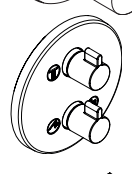

102

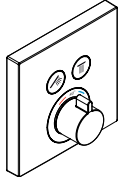

62, 72,  
74, 78

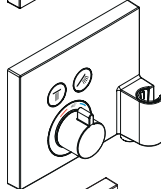

70

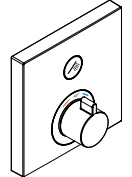

64 - 68

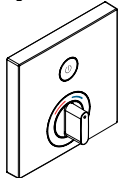

64 - 68

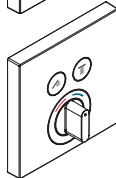

62, 72,  
74, 78

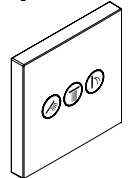

92,  
98 - 102,  
110 - 114

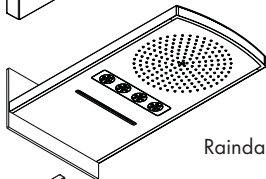

92, 94

Raindance Rainfall 240

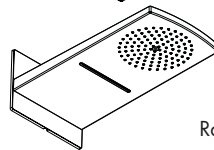

106 - 110

Raindance Rainfall 180

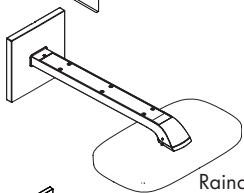

100

Raindance Select E 300

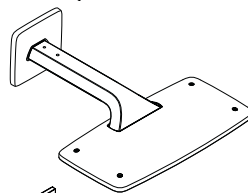

102, 104

Raindance E 420

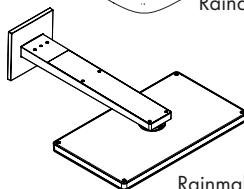

112

Rainmaker Select 460 2jet

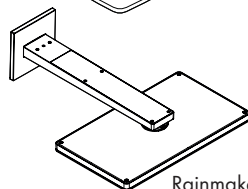

114

Rainmaker Select 460 3jet



- Příklady instalace s údaji o rozměrech a dimenzování potrubí jsou uvedeny od strany 60.
- Montážní rozměry uvedené v návodu pro montáž jsou ideální pro osoby s výškou postavy přibližně 1800 mm a v případě potřeby je nutné je přizpůsobit. Při tom je zapotřebí dbát nato, že se při změně výšce montáže změní požadovaná minimální výška a že je třeba brát ohled na připojovací rozměry.
- Spotřební hodnoty byly v praxi měřeny na příslušných armaturách (termostat/baterie/podomítkový ventil).
- iBox v kombinaci s vanovým napouštěním Exafill s odpadní a přeřadovou garniturou (viz strana 60)

## Popis symbolů

**X**

Střed koupací vany / Střed sprchové vany

**Y**

Rozměr Y = vzdálenost středu připojení sprchové hadice od středu vanového napouštění dělitelná 2 (eventuelně přizpůsobit rozměru obkladů).



Teplá voda



Studená voda



Od • je zaručená funkce



V této oblasti je potřebné zesílení stěny.



Je možné použít pouze jeden spotřebič, ne dva současně.



% Vodovodní potrubí pro boční sprchy nainstalovat se spádem.



výplachový blok kompl. #15956000



Podomítkový uzavírací ventil



Quattro čtyřcestné přestavování



Trio Universal - Uzavírací a přepínací ventil



Vanový vtok



Nepoužitý vývod musí být utěsněn zaslepovací zátkou. (DN20, 3/4")



Odtokový výkon musí být vyšší než 50 l/min.



Odtok



iBox v kombinaci s vanovým napouštěním Exafill s odpadní a přeřadovou garniturou

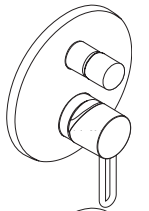

62, 72,  
74

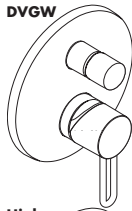

**DVGW**

60

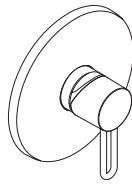

64 - 68,  
82

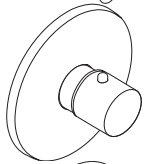

76, 80,  
84

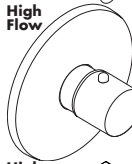

**High Flow**

86 - 90,  
94, 96,  
102 - 112

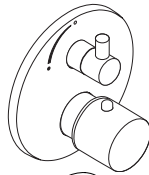

64 - 68,  
82

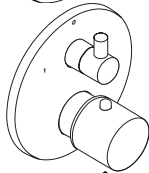

62, 72,  
74, 78

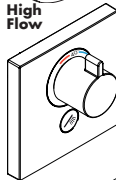

**High Flow**

92, 98,  
100, 114

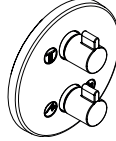

102

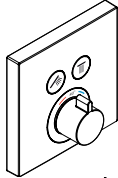

62, 72,  
74, 78

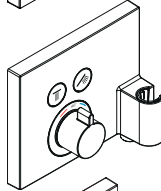

70

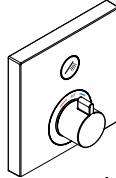

64 - 68

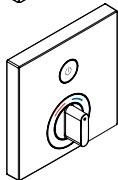

64 - 68

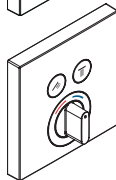

62, 72,  
74, 78

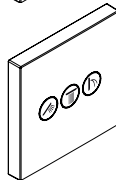

92,  
98 - 102,  
110 - 114

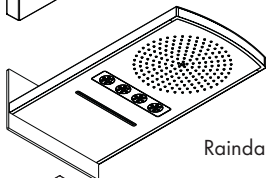

92, 94

Raindance Rainfall 240

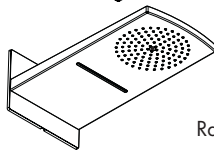

106 - 110

Raindance Rainfall 180

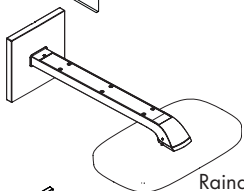

100

Raindance Select E 300

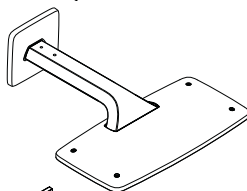

102, 104

Raindance E 420

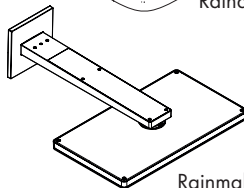

112

Rainmaker Select 460 2jet

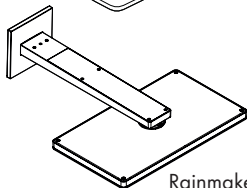

114

Rainmaker Select 460 3jet



iBox kombinovaný s EXAFILL vaňovým napúšťaním s odpadovou a prepádovou garnitúrou

- Inštaláčne príklady s uvedením rozmerov a výkonov nájdete od strany 60.
- Montážne rozmery uvedené v návode na montáž sú ideálne pre osoby s výškou postavy približne 1800 mm a v prípade potreby je nutné ich prispôbiť. Pritom je nutné si uvedomiť, že pri zmenenej výške montáže sa mení minimálna výška a a je nutné dbať na rozmery rozmiestnenia prípojk.
- Hodnoty spotreby boli merané blízko praxe s príslušnými armatúrami (termostat/zmiešavacia batéria/ventil pod omietku).
- iBox kombinovaný s EXAFILL vaňovým napúšťaním s odpadovou a prepádovou garnitúrou (viď strana 60)

## Popis symbolov

**X**

Stred vane / Stred sprchovej vane

**Y**

Rozmer Y = vzdialenosť stredy pripojenia sprchovej hadice od stredy vaňového napúšťania deliteľná 2 (prípadne prispôbiť rozmeru obkladu)



Teplá voda



Studená voda



Od • je zaručená funkcia.



V tejto oblasti je potrebné zosilnenie steny.



Je možné používať len jeden spotrebič, nie oba súčasne.



% Vodovodné potrubie pre bočné sprchy vypádovať.



Kompletný vyplachovací blok #15956000



Podomietkový uzatvárací ventil



Quattro štvorcestné prestavenie



Trio univerzálny uzatvárací a prestavovací ventil



Vaňový vtok



Nepoužitý vývod musí byť zaslepený zátkou. (DN20, 3/4")



Výkon odtoku musí byť vyšší ako 50 l/min.



Odtok

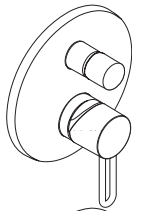

62, 72,  
74

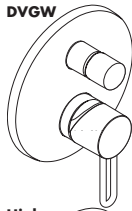

DVGW

60

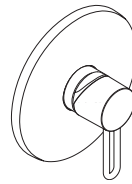

64 - 68,  
82

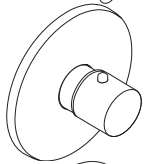

76, 80,  
84

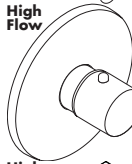

High  
Flow

86 - 90,  
94, 96,  
102 - 112

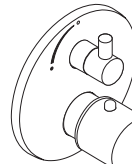

64 - 68,  
82

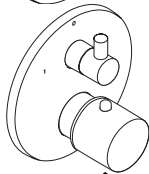

62, 72,  
74, 78

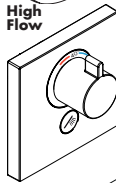

High  
Flow

92, 98,  
100, 114

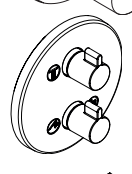

102

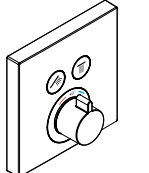

62, 72,  
74, 78

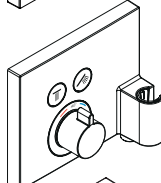

70

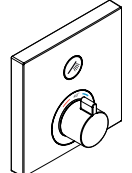

64 - 68

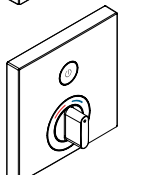

64 - 68

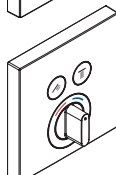

62, 72,  
74, 78

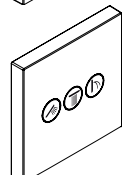

92,  
98 - 102,  
110 - 114

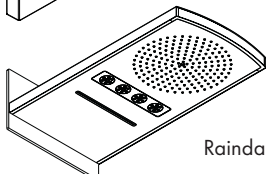

92, 94

Raindance Rainfall 240

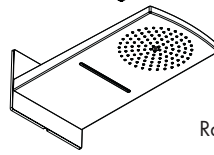

106 - 110

Raindance Rainfall 180

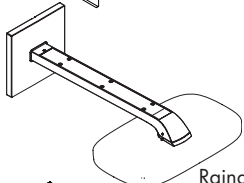

100

Raindance Select E 300

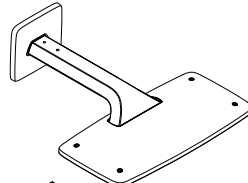

102, 104

Raindance E 420

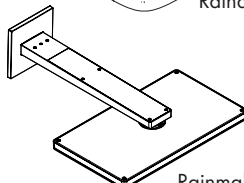

112

Rainmaker Select 460 2jet

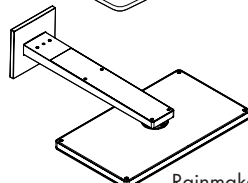

114

Rainmaker Select 460 3jet



- 带数据和管道尺寸的安装实例请从 60 页起查找。
- 本安装说明中所规定的安装尺寸理想用于身高 1800 mm 左右的人士。尺寸可根据需要进行修改。在这种情况下，您必须留意，如果安装高度改变，则花洒到地板的最小高度也随之改变，且必须考虑到连接尺寸的改变。
- 已根据实际情况测量相关龙头（恒温器/冷热水龙头/反水阀）的消耗值。
- iBox与下水部件组合，配备出水组件及溢流组件（参见第页 60）

## 符号说明

**X**

槽中间 / 中心淋浴盆

**Y**

尺寸Y = 软管壁出口弯管的中心至浴盆加水口中心除以2（匹配瓷砖布置）。



热水



冷水



从•开始，正常功能得以保证。



该区域需要一个加固边壁。



只有一项功能。



安装水管，用于带有梯度的淋浴器。



全套清洗端 #15956000



截止阀



Quattro 四通转换器



通用的三通截止阀和换向阀



浴缸出水口



插入不使用的插座。（DN20, 3/4"）



排水功率必须大于 50 l/min。



排水口



iBox与下水部件组合，配备出水组件及溢流组件



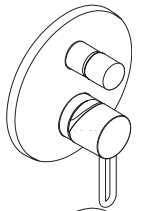

62, 72,  
74

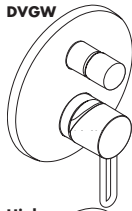

DVGW

60

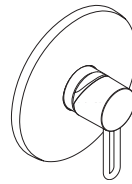

64 - 68,  
82

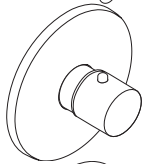

76, 80,  
84

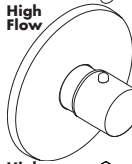

High  
Flow

86 - 90,  
94, 96,  
102 - 112

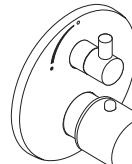

64 - 68,  
82

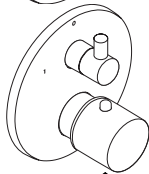

62, 72,  
74, 78

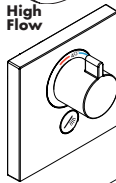

High  
Flow

92, 98,  
100, 114

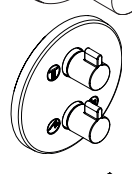

102

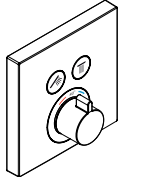

62, 72,  
74, 78

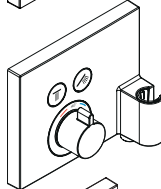

70

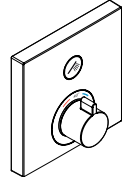

64 - 68

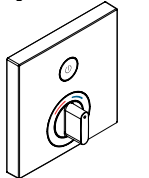

64 - 68

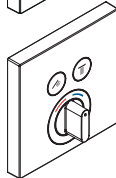

62, 72,  
74, 78

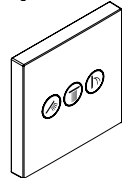

92,  
98 - 102,  
110 - 114

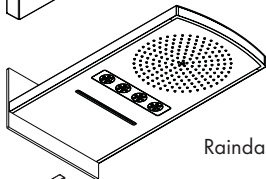

92, 94

Raindance Rainfall 240

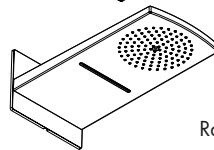

106 - 110

Raindance Rainfall 180

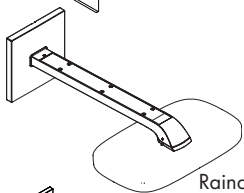

100

Raindance Select E 300

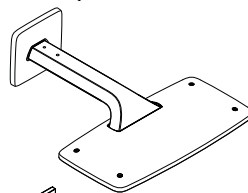

102, 104

Raindance E 420

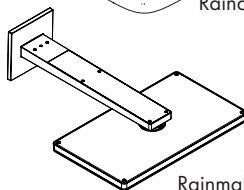

112

Rainmaker Select 460 2jet

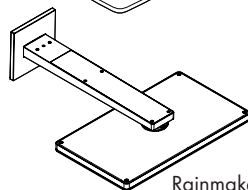

114

Rainmaker Select 460 3jet



iVox в комбинации со впуском ванны Exafill со сливной и переливной гарнитурой

- Примеры монтажа с указанием размеров и размеры трубопровода см. на стр. 60.
- Указанные в монтажной инструкции монтажные размеры идеальны для лиц ростом около 1800 мм. В случае необходимости монтажные размеры следует менять. При этом нужно учесть, что при изменившейся высоте монтажа меняется также и минимальная высота, а изменение установочных размеров нужно принять во внимание.
- Расход измерен практически с помощью соответствующей арматуры (термостат/смеситель/скрытый клапан).
- iVox в комбинации со впуском ванны Exafill со сливной и переливной гарнитурой (см. стр. 60)

## Описание символов

**X** середина ванны / Середина душевой ванны

**Y** Размер Y = середина дуги подключения шланга, деленная на 2 (или подогнать по растр плитки).

 Теплая вода

 Холодная вода

 Гарантированное функционирование при показателях свыше •.

 В этой области требуется укрепление стены.

 Возможно использование только одного потребителя, не двух одновременно.

 % Водопроводы для боковых душей прокладывают под наклоном .

 промывочный блок кпл. #15956000

 Скрытый вентиль

 Четырехходовой переключатель Quattro

 Трехходовой запорный и переключающий вентиль Trio Universal

 Водозабор

 Ненужный выход необходимо уплотнить с помощью заглушки. (DN20, 3/4")

 Слив должен иметь производительность более 50 л/мин.

 Слив

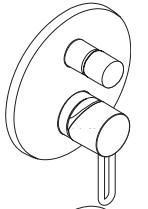

62, 72,  
74

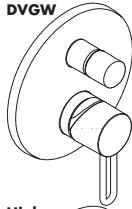

DVGW

60

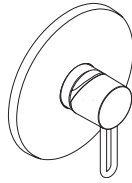

64 - 68,  
82

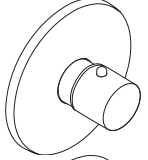

76, 80,  
84

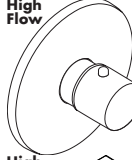

High Flow

86 - 90,  
94, 96,  
102 - 112

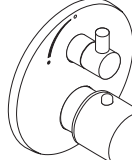

64 - 68,  
82

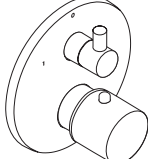

62, 72,  
74, 78

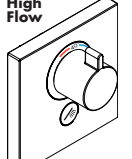

High Flow

92, 98,  
100, 114

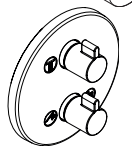

102

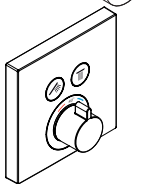

62, 72,  
74, 78

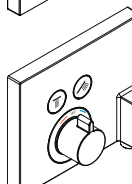

70

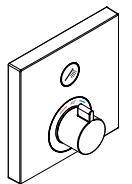

64 - 68

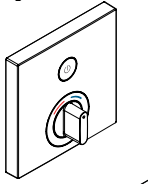

64 - 68

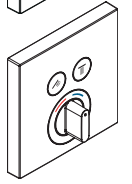

62, 72,  
74, 78

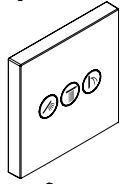

92,  
98 - 102,  
110 - 114

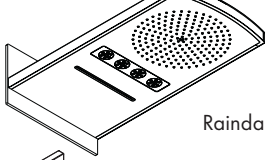

92, 94

Raindance Rainfall 240

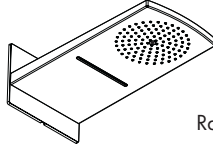

106 - 110

Raindance Rainfall 180

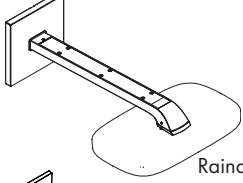

100

Raindance Select E 300

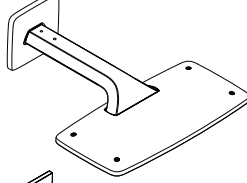

102, 104

Raindance E 420

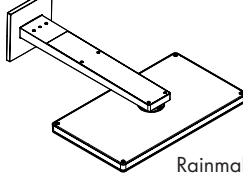

112

Rainmaker Select 460 2jet

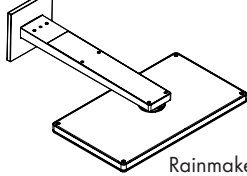

114

Rainmaker Select 460 3jet



- Asennusesimerkit mittoineen ja putkitietoineen löytyvät alkaen sivulta 60.
- Asennusohjeessa annetut asennusmitat sopivat n. 180 cm:n pituiselle henkilölle, ja niitä on tarvittaessa muutettava. Tässä on otettava huomioon, että asennuskorkeuden muuttuessa muuttuu myös vähimmäiskorkeus, ja muutos on otettava huomioon liitäntöjen mitoissa.
- Kulutusarvot on mitattu käytännönläheisesti kaikkine armatureineen (termostaatti/sekoitin/seinäventtiili).
- iBox yhdessä Exafill ammeentäyttöhana varustettuna tyhjennys- ja ylivuotovarusteilla (katso sivu 60)

## Merkin kuvaus

**X**

Ammeen keskusta / Suihkualtaan keskusta

**Y**

Mitta Y = etäisyys letkunliitäntäkaaren keskeltä ammeen tuloaukon keskelle jaettuna kahdella (sovitus mahdollisesti laattaruudukkoon).



Lämmin vesi



Kylmä vesi



Tämä toiminta on taattuna • alkaen.



Tässä kohdassa seinää on vahvistettava



Vain yksi vedenkäyttöpiste kerrallaan on mahdollista, ei kahta samanaikaisesti.



% Vie sivusuihkujen syöttöputket alaspäin laskevasti.



Huuhtelulohko, täyd. #15956000



Upotettava venttiili



4-tiesäätöventtiili



Trio -sulku- ja säätöventtiili



Vedentulo ammeeseen



Käyttämätön lähtöliitin on suljettava sulkutulpalla. (DN20, 3/4")



Poisvirtaustehon on oltava enemmän kuin 50l/min.



Veden poisvirtaus



iBox yhdessä Exafill ammeentäyttöhana varustettuna tyhjennys- ja ylivuotovarusteilla

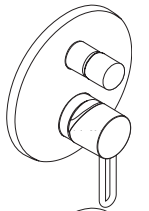

62, 72,  
74

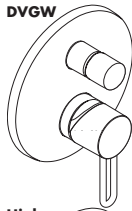

DVGW

60

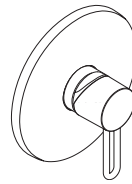

64 - 68,  
82

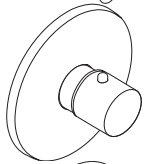

76, 80,  
84

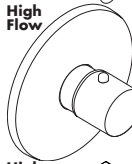

High  
Flow

86 - 90,  
94, 96,  
102 - 112

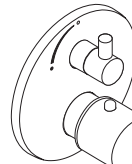

64 - 68,  
82

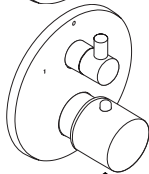

62, 72,  
74, 78

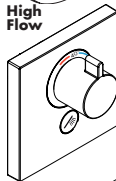

High  
Flow

92, 98,  
100, 114

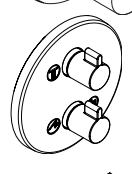

102

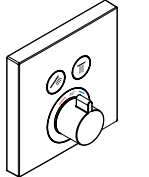

62, 72,  
74, 78

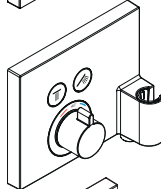

70

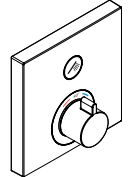

64 - 68

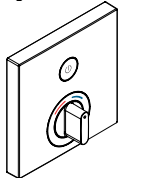

64 - 68

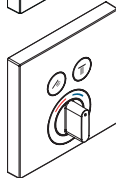

62, 72,  
74, 78

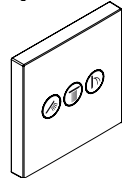

92,  
98 - 102,  
110 - 114

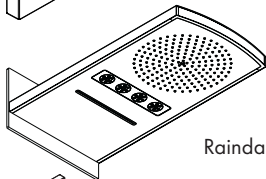

92, 94

Raindance Rainfall 240

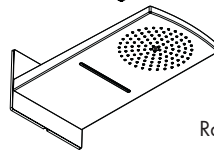

106 - 110

Raindance Rainfall 180

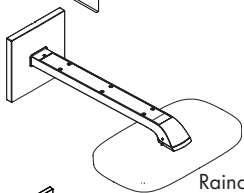

100

Raindance Select E 300

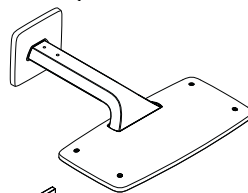

102, 104

Raindance E 420

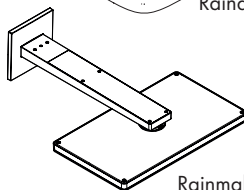

112

Rainmaker Select 460 2jet

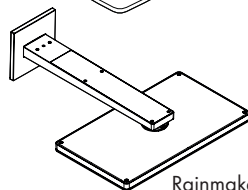

114

Rainmaker Select 460 3jet



- Du hittar installationsexempel med uppgifter om mått och ledningsdimensioner från sidan 60.
- De monteringsmått som anges i monteringsanvisningen passar 1,80 m långa personer och måste eventuellt anpassas. Det är då viktigt att tänka på att den minsta höjden ändras när monteringshöjden blir en annan och att hänsyn måste tas till de ändrade anslutningsmått.
- Förbrukningsvärdena uppmättes under användning med de tillhörande armaturerna (termostat/blandare/infälld ventil).
- iBox i kombination med ett Exafill karinlopp med från- och överrinningsset (se sidan 60)

## Symbolförklaring

**X**

Mitt på badkar / Mitten av duschkaret

**Y**

Mått Y = mitten av slanganslutningskrök till mitten av karinlopp delat med två (anpassa eventuellt till kakelmönstret).



Varmvatten



Kallvatten



Från • garanteras funktionen.



Šioje zonoje būtinas sienos sutvirtinimas



Endast en enhet möjlig, inte två samtidigt.



Drag vattenledningar till sidoduschar med fall.



Spolblock kompl. #15956000



Invändig ventil



Quattro Fyrvägsomkastare



Trio Universell avstängningsventil och omkastare



Badkarskran



Det utlopp som inte behövs måste tätas med en blindstopp. (DN20, 3/4")



Avloppet måste klara mer än 50 l/min.



Avlopp



iBox i kombination med ett Exafill karinlopp med från- och överrinningsset

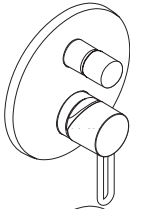

62, 72,  
74

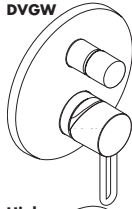

DVGW

60

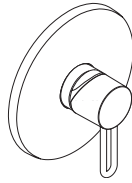

64 - 68,  
82

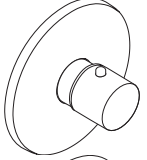

76, 80,  
84

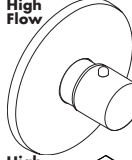

High  
Flow

86 - 90,  
94, 96,  
102 - 112

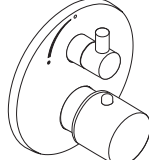

64 - 68,  
82

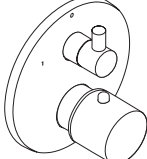

62, 72,  
74, 78

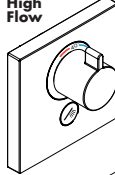

High  
Flow

92, 98,  
100, 114

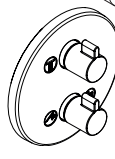

102

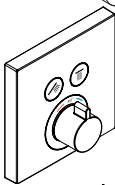

62, 72,  
74, 78

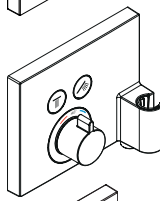

70

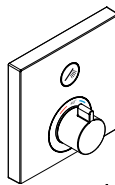

64 - 68

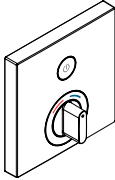

64 - 68

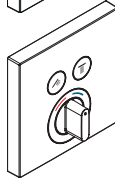

62, 72,  
74, 78

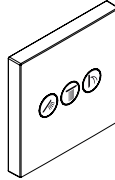

92,  
98 - 102,  
110 - 114

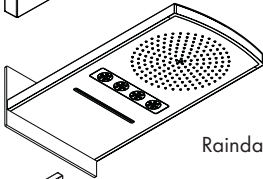

92, 94

Raindance Rainfall 240

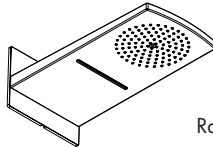

106 - 110

Raindance Rainfall 180

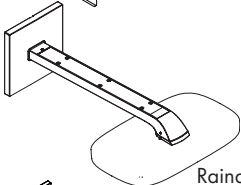

100

Raindance Select E 300

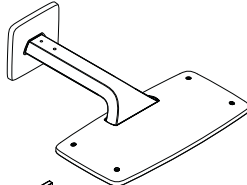

102, 104

Raindance E 420

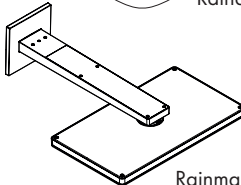

112

Rainmaker Select 460 2jet

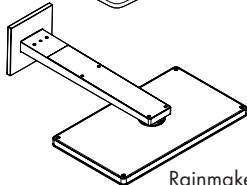

114

Rainmaker Select 460 3jet



- Įrengimo pavyzdžiai su nurodytais matmenimis ir vamzdyno dydžiais pateikti 60 puslapyje.
- Montavimo instrukcijoje nurodyti išmatavimai idealiai tinka 1800 mm ūgio žmonėms. Galima keisti aukštį, bet tuomet keičiasi minimalus rekomenduojamas patalpos aukštis ir turi būti atsižvelgta į vandens jungties matmenų pasikeitimą.
- Sąnaudų išmatuotos artimomis realioms sąlygomis su reikiamomis dalimis (termostatu / maišytuvu / potinkiniu čiaupu).
- iBox kartu su Exafill vonios čiaupu ir išleidimo bei apsauginės angos rinkiniais (žr. psl. 60)

## Simbolio aprašymas

**X**

Vonios vidurys / Dušo padėklo centras

**Y**

Matmuo Y = atstumas nuo dušo žarnos jungties centro iki čiaupo centro, padalintas iš 2 (jei įmanoma, taikykite prie plytelių).



Šiltas vanduo



Šaltas vanduo



Nuo • funkcionavimas garantuotas



Šioje zonoje būtinas sienos sutvirtinimas



Vienu metu galima tik viena funkcija.



% Privesti vamzdžius šoniniams purkštukams.



Plaunamojo bloko jungtis #15956000



Potinkinis uždarymo vožtuvas



„Quattro“ 4-krypčių perjungimas



Užtvarinis ir perjungimo vožtuvas „Trio Universal“



Vonios įeiga



Nenaudojamą išėjimą užaklinti. (DN20, 3/4")



Nutekėjimo našumas turi būti ne mažesnis  
50 l/min



Nutekėjimas



iBox kartu su Exafill vonios čiaupu ir išleidimo bei apsauginės angos rinkiniais



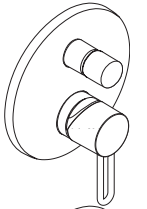

62, 72,  
74

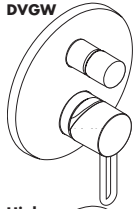

DVGW

60

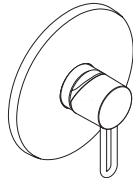

64 - 68,  
82

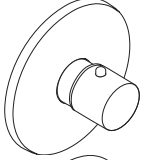

76, 80,  
84

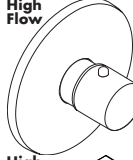

High  
Flow

86 - 90,  
94, 96,  
102 - 112

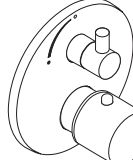

64 - 68,  
82

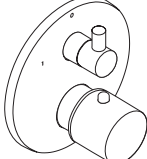

62, 72,  
74, 78

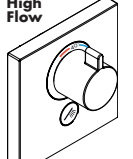

High  
Flow

92, 98,  
100, 114

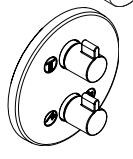

102

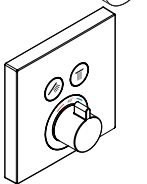

62, 72,  
74, 78

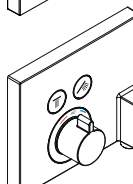

70

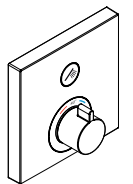

64 - 68

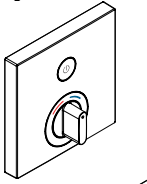

64 - 68

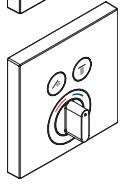

62, 72,  
74, 78

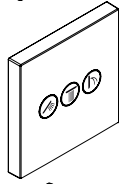

92,  
98 - 102,  
110 - 114

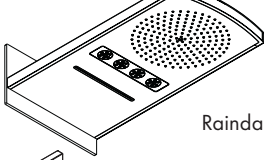

92, 94

Raindance Rainfall 240

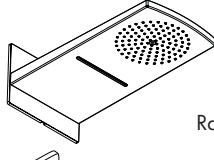

106 - 110

Raindance Rainfall 180

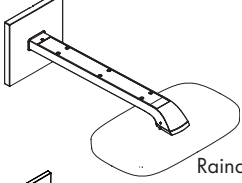

100

Raindance Select E 300

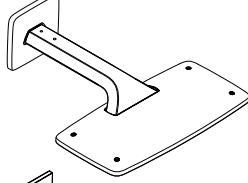

102, 104

Raindance E 420

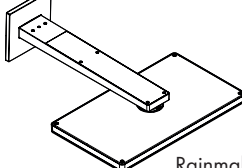

112

Rainmaker Select 460 2jet

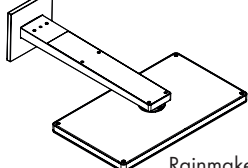

114

Rainmaker Select 460 3jet



iBox u kombinaciji s Exafill ispustom u kadu s odvodnom i preljevnom garniturom

- Primjeri instalacija s veličinama i dimenzijama vodova mogu se naći od stranice 60 nadalje.
- Montažne dimenzije navedene u uputama za montažu idealne su za osobe visine oko 1800 mm te se prema potrebi moraju prilagoditi konkretnoj visini korisnika. Pritom valja uzeti u obzir da se u slučaju promjene montažne visine mijenja i minimalna visina kao i da se tada mora uvažiti i promjena priključnih dimenzija.
- Vrijednosti potrošnje u praksi mjerene su s pripadajućim armaturama (termostat/mješač/podžbukni ventil).
- iBox u kombinaciji s Exafill ispustom u kadu s odvodnom i preljevnom garniturom (pogledaj stranicu 60)

## Opis simbola

**X**

Sredina kade / Sredina tuš-kada

**Y**

Mjera Y = sredina priključka crijeva do sredine filtera kade podijeljeno sa 2 (eventualno prilagoditi rasteru pločica)



Topla voda



Hladna voda



Zajamčena funkcija od • naviše



U ovom je području potrebno ojačanje zida.



Moguće je koristiti samo jedno trošilo, nikako dva istovremeno!



% Položite vodovodne cijevi za bočni tuš s nagibom



kompletni blok # 15956000



Podžbukni ventil



Quattro četverostruki preusmjerivač



Trio Universal ventil za zatvaranje i ventil selektora



Ispust u kadu



Potrebno je ostaviti zatvoren izlaz koji se ne koristi (DN20, 3/4")



Protok vode mora biti veći od 50 l/min.



Odvod

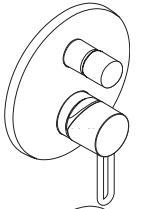

62, 72,  
74

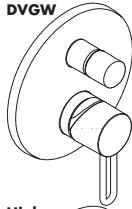

DVGW

60

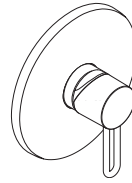

64 - 68,  
82

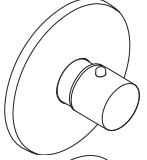

76, 80,  
84

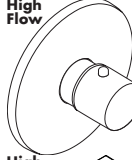

High Flow

86 - 90,  
94, 96,  
102 - 112

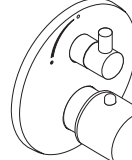

64 - 68,  
82

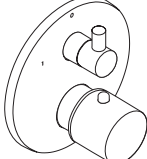

62, 72,  
74, 78

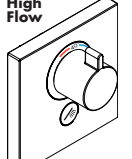

High Flow

92, 98,  
100, 114

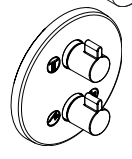

102

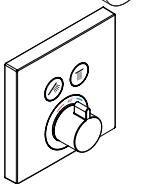

62, 72,  
74, 78

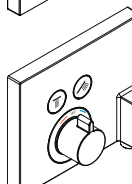

70

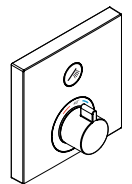

64 - 68

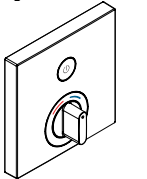

64 - 68

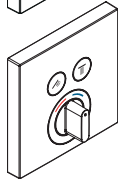

62, 72,  
74, 78

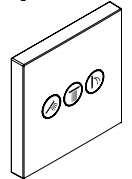

92,  
98 - 102,  
110 - 114

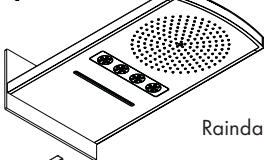

92, 94

Raindance Rainfall 240

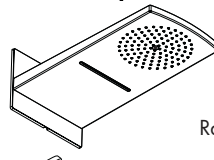

106 - 110

Raindance Rainfall 180

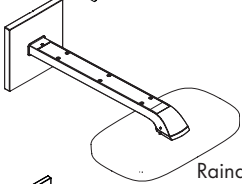

100

Raindance Select E 300

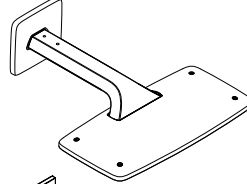

102, 104

Raindance E 420

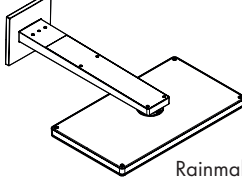

112

Rainmaker Select 460 2jet

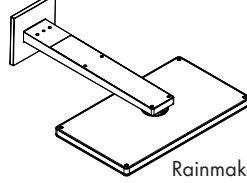

114

Rainmaker Select 460 3jet



- Ölçü verileri ve hat boyutlandırıcılı tesisat örnekleri Sayfa 60 itibariyle bulunabilir.
- Montaj kılavuzunda belirtilen montaj ölçüleri, yaklaşık 1.800 mm boyundaki kişiler için idealdir ve gerekirse adapte edilmelidir. Bu sırada, montaj yüksekliğinin değişmesiyle birlikte minimum yüksekliğin de değiştiğine ve bağlantı ölçülerindeki değişikliğin göz önüne alınması gerektiğine dikkat edilmelidir.
- Tüketim değerleri uygulamalı olarak ilgili armatürlerle (termostat/karıştırıcı/sıva altı valf) ölçülmüştür.
- Çıkış ve taşma aksesuarlı bir Exafill batarya girişiyle bağlantılı iBox (bakınız sayfa 60)

## Simge açıklaması

**X**

Küvetin ortası / Duş küvetinin ortası

**Y**

Y = Hortum bağlantı kavisinin ortasından küvet girişinin ortası arasındaki ölçü 2'ye bölünür (gerekirse fayans bölümlerine adapte edin).



Sıcak su



Soğuk su



•'den itibaren fonksiyon garanti edilmiştir.



Bu alanda duvarın kalınlaştırılması gereklidir.



Sadece bir tüketici mümkündür, aynı anda iki tüketici mümkün değildir.



% Yan duşların su hatlarını eğimli şekilde döşeyin.



Yıkama bloğu komple #15956000



Sıva altı valfi



Quattro dört yöllu değiştirme



Trio üniversal kapatma ve değiştirme valfi



Küvet su girişi



Kullanılmayan çıkış bir kör tapayla izole edilmelidir. (DN20, 3/4")



Akış kapasitesi 50 l/dak üzerinde olmalıdır.



Akış



Çıkış ve taşma aksesuarlı bir Exafill batarya girişiyle bağlantılı iBox

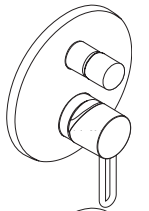

62, 72,  
74

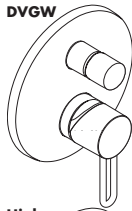

DVGW

60

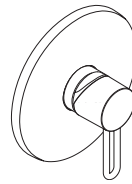

64 - 68,  
82

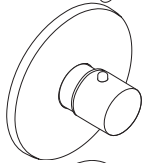

76, 80,  
84

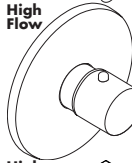

High  
Flow

86 - 90,  
94, 96,  
102 - 112

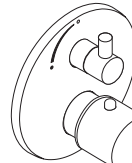

64 - 68,  
82

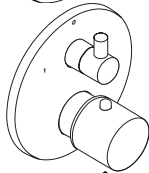

62, 72,  
74, 78

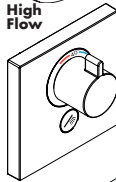

High  
Flow

92, 98,  
100, 114

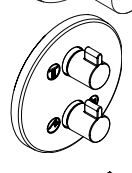

102

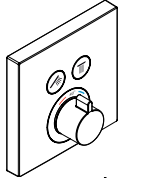

62, 72,  
74, 78

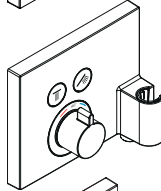

70

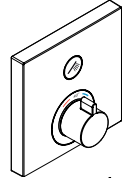

64 - 68

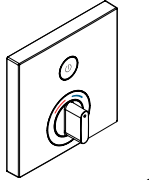

64 - 68

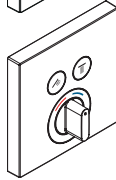

62, 72,  
74, 78

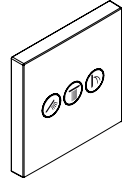

92,  
98 - 102,  
110 - 114

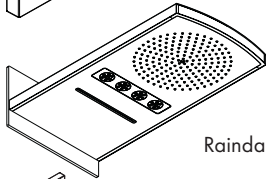

92, 94

Raindance Rainfall 240

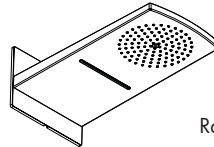

106 - 110

Raindance Rainfall 180

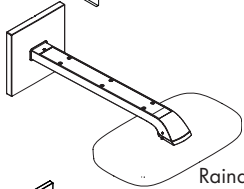

100

Raindance Select E 300

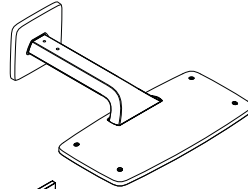

102, 104

Raindance E 420

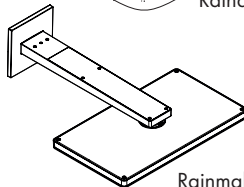

112

Rainmaker Select 460 2jet

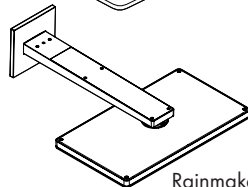

114

Rainmaker Select 460 3jet



- Exemplele de montaj cu specificații referitoare la dimensiuni și capacitate se găsesc începând de la pagina 60.
- Dimensiunile de montare din instrucțiunile de montare sunt ideale pentru persoane cu o înălțime de cca. 1800 mm și trebuie modificate dacă este cazul. Aici trebuie să ții cont de modificarea înălțimii de montare, deoarece în acest caz se va modifica și înălțimea minimă de montare și astfel trebuie modificate toate dimensiunile de racordare.
- Rile de consum au fost măsurate pe teren cu armăturile corespunzătoare (termostat, robinet de amestecare, supapă sub tencuială).
- Cutie iBox în combinație cu Exafill pe intrarea în cadă, cu un set pentru evacuare și deversare. (vezi pag. 60)



Capacitatea de evacuare trebuie să fie mai mare de 50 l/min.



Deversor

Cutie iBox în combinație cu Exafill pe intrarea în cadă, cu un set pentru evacuare și deversare.

## Descrierea simbolurilor

**X** Cadă de baie în mijloc / În mijlocul căzii de duș

**Y** Dimensiune Y = distanța între mijlocul racordului pentru furtună și intrare cadă împărțită la doi (eventual potrivit la suprafața tencuielii).



Apă caldă



Apă rece



Începând de la • funcționarea este garantată.



În această zonă este nevoie de întărirea peretelui.



Se poate conecta numai un singur consumator, nu se pot conecta doi în același timp.



% Montați conductele de apă înclinate (în cădere) pentru dușurile laterale.



Complet spălare #15956000



Ventil montat sub tencuială



Quattro valvă de inversare cu patru căi



Trio valvă de închidere și de inversare universală



Gură de admisiune



Racordurile neutilizate trebuie acoperite cu dop etanș. (DN20, 3/4")

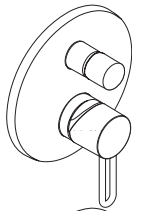

62, 72,  
74

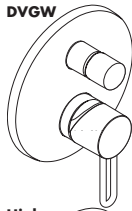

DVGW

60

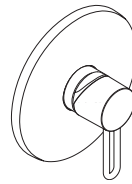

64 - 68,  
82

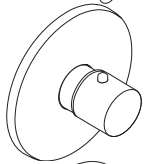

76, 80,  
84

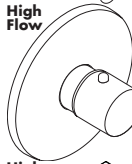

High Flow

86 - 90,  
94, 96,  
102 - 112

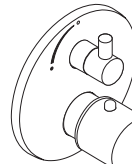

64 - 68,  
82

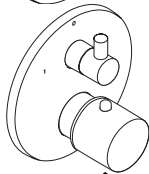

62, 72,  
74, 78

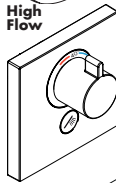

High Flow

92, 98,  
100, 114

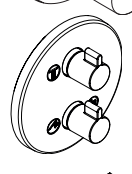

102

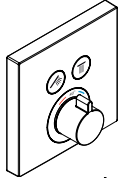

62, 72,  
74, 78

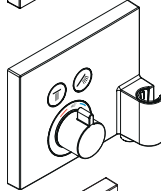

70

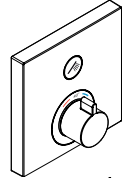

64 - 68

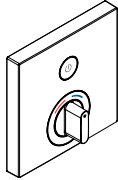

64 - 68

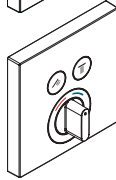

62, 72,  
74, 78

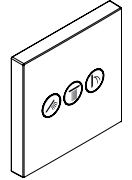

92,  
98 - 102,  
110 - 114

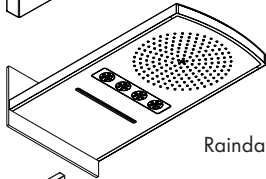

92, 94

Raindance Rainfall 240

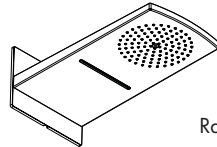

106 - 110

Raindance Rainfall 180

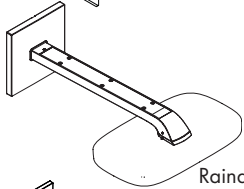

100

Raindance Select E 300

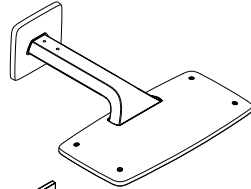

102, 104

Raindance E 420

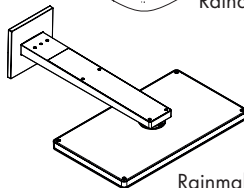

112

Rainmaker Select 460 2jet

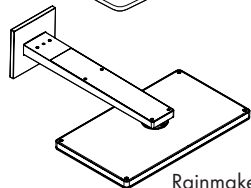

114

Rainmaker Select 460 3jet



- Παραδείγματα εγκατάστασης με διαστάσεις και διαστασιολόγηση των σωλήνων θα βρείτε από τη σελίδα 60.
- Οι διαστάσεις που αναφέρονται στις οδηγίες συναρμολόγησης είναι ιδανικές για άτομα με ύψος περ. 1800 mm και πρέπει, εάν χρειαστεί, να προσαρμοστούν. Στη φάση αυτή προσέξτε ότι με την αλλαγή του ύψους συναρμολόγησης τροποποιείται και το απαιτούμενο ελάχιστο ύψος, οπότε θα προκύψει αλλαγή και στις διαστάσεις σύνδεσης.
- Οι τιμές κατανάλωσης μετρήθηκαν στην πράξη με τα ανάλογα εξαρτήματα μπαταρίας (θερμοστάτης/ αναμικτήρας/εντοιχισμένη βαλβίδα).
- iBox σε συνδυασμό με είσοδο νερού μπανιέρας Exafill με απορροή και εξοπλισμό υπερχείλισης (βλ. Σελίδα 60)



Η αποχετευτική ικανότητα της βαλβίδας εκροής πρέπει να υπερβαίνει τα 1/min.



Βαλβίδα εκροής

iBox σε συνδυασμό με είσοδο νερού μπανιέρας Exafill με απορροή και εξοπλισμό υπερχείλισης

## Περιγραφή συμβόλων

**X**

Κέντρο μπανιέρας / Μέσον της ντουσιέρας

**Y**

Μέγεθος X = από το μέσον του τόξου σύνδεσης του εύκαμπτου σωλήνα έως το μέσον της εισόδου της μπανιέρας, δια του 2 (ενδεχομένως να πρέπει να προσαρμοστεί στο ράστερ των πλακιδίων).



Ζεστό νερό



Κρύο νερό



Αυτή η λειτουργία διασφαλίζεται από το σημείο κι έπειτα



Σε αυτήν την περιοχή είναι απαραίτητη μία ενίσχυση του τοίχου.



Μόνο ένας χρήστης, όχι δύο ταυτόχρονα



% Εγκαταστήστε τους αγωγούς νερού του καταιονιστήρα σώματος με κλίση.



Μπλοκ ξεπλύματος κομπλέ #15956000



Χωνευτή βαλβίδα



Quattro τετράοδης μετατροπής



Trio Universal βαλβίδα κλεισίματος και εκτροπής



Είσοδος νερού στη μπανιέρα



Τα περιττά στόμια εξόδου πρέπει να στεγανοποιηθούν με ένα τυφλό πώμα. (DN20, 3/4")



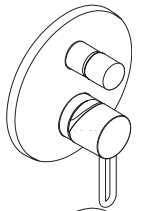

62, 72,  
74

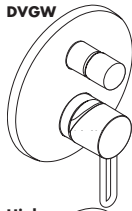

DVGW

60

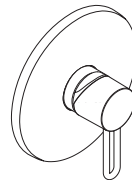

64 - 68,  
82

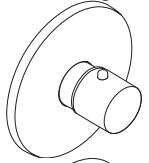

76, 80,  
84

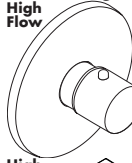

High  
Flow

86 - 90,  
94, 96,  
102 - 112

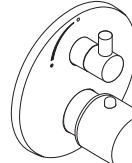

64 - 68,  
82

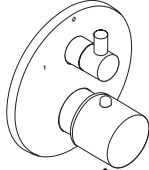

62, 72,  
74, 78

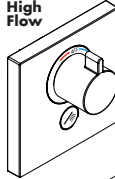

High  
Flow

92, 98,  
100, 114

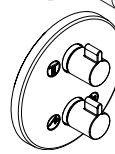

102

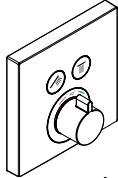

62, 72,  
74, 78

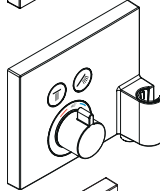

70

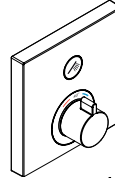

64 - 68

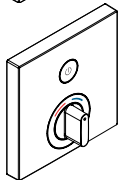

64 - 68

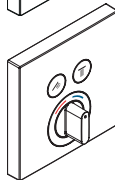

62, 72,  
74, 78

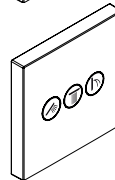

92,  
98 - 102,  
110 - 114

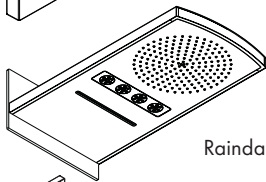

92, 94

Raindance Rainfall 240

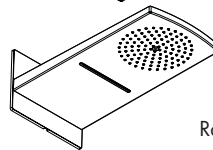

106 - 110

Raindance Rainfall 180

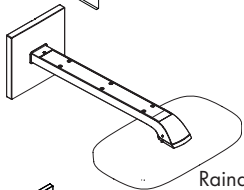

100

Raindance Select E 300

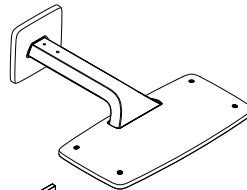

102, 104

Raindance E 420

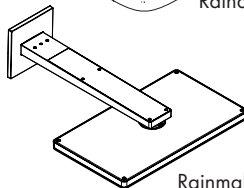

112

Rainmaker Select 460 2jet

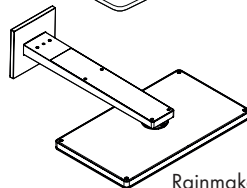

114

Rainmaker Select 460 3jet



- Inštalacijske primere z navedbami mer in dimenzioniranjem cevi najdete od strani 60 dalje.
- V navodilu za montažo navedene mere so idealne za osebe, visoke pribl. 1800 mm, in jih je treba po potrebi prilagoditi. Pri tem morate paziti na to, da se pri spremenjeni montažni višini spremeni tudi minimalna višina in je treba upoštevati spremembo priključnih mer.
- Vrednosti porabe so bile s pripadajočimi armaturami (termostat/mešalni ventil/podometni ventil) izmerjene v pogojih, ki ustrezajo predvideni dejanski uporabi.
- iBox v kombinaciji z Exafill dovodom za kopalno kad z odtočno in pretočno garnituro (glejte stran 60)

## Opis simbola

**X** Sredina kopalne kadi / Sredina pršne kadi

**Y** Mera Y = sredina loka priključka za cev do sredine dotoka v kad deljeno z 2 (morebiti prilagoditi vzorcu ploščic)

 Topla voda

 Mrzla voda

 Od • je delovanje zagotovljeno.

 V tem območju je potrebno ojačanje stene.

 Mogoč je samo en uporabnik, ne dva istočasno.

 % Položite vodovodne cevi za stranske šobe z naklonom.

 Ventil za vodo, kpl. #15956000

 Podometni ventil

 Quattro  
Quattro 4tiripotna prestavitev

 Trio  
Trio Universal zaporni in preklopni ventil

 Vtok v kad

 Izhod, ki ga ne potrebujete, zatesnite s čepom. (DN20, 3/4")

 > 50 l/min  
Odtočna kapacitetamora znašati več kot 50 l/min.

 Odtok

 Exafill  
iBox v kombinaciji z Exafill dovodom za kopalno kad z odtočno in pretočno garnituro

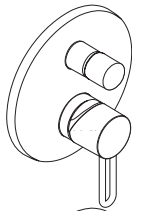

62, 72,  
74

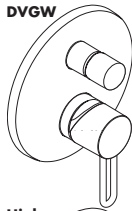

DVGW

60

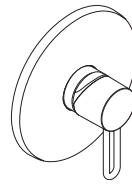

64 - 68,  
82

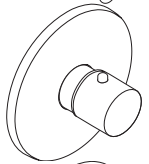

76, 80,  
84

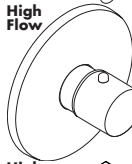

High  
Flow

86 - 90,  
94, 96,  
102 - 112

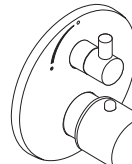

64 - 68,  
82

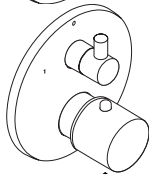

62, 72,  
74, 78

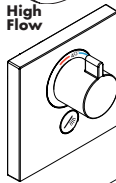

High  
Flow

92, 98,  
100, 114

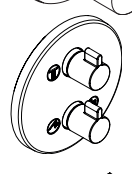

102

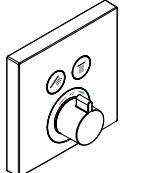

62, 72,  
74, 78

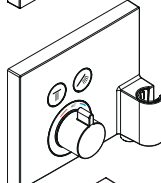

70

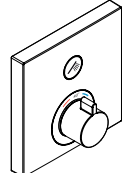

64 - 68

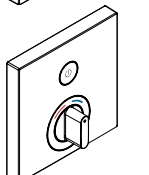

64 - 68

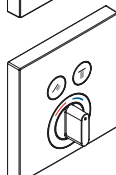

62, 72,  
74, 78

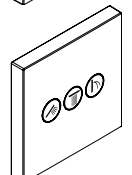

92,  
98 - 102,  
110 - 114

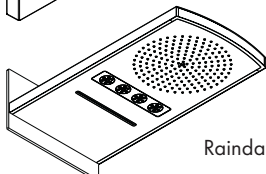

92, 94

Raindance Rainfall 240

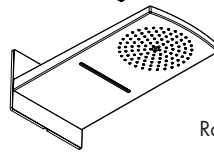

106 - 110

Raindance Rainfall 180

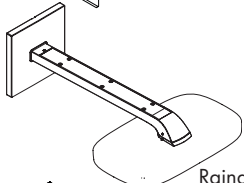

100

Raindance Select E 300

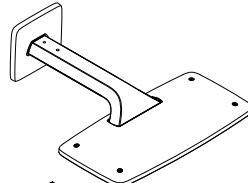

102, 104

Raindance E 420

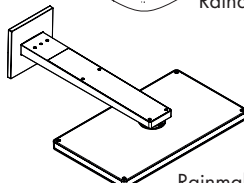

112

Rainmaker Select 460 2jet

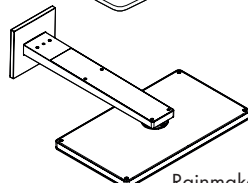

114

Rainmaker Select 460 3jet



- Paigaldusnäited koos mõõtude info ja voolikute suurustega leiate alates leheküljest 60.
- Paigaldusjuhendis esitatud paigaldusmõõdud on ideaalsed u. 1800 mm pikkustele inimestele ning vajadusel tuleb neid kohandada. Seejuures tuleb silmas pidades, et muutunud paigalduskõrguse korral muutub ka minimaalne kõrgus ning tuleb arvestada, et erinevad on ka ühendusmõõdud.
- Tarbimisväärtusi mõõdeti praktikas juurdekuuluvate armatuuridega (termostaat/segisti/krohvalune ventiil).
- iBox ühenduses ära- ja ülevoolugarnituuriga Exafilli vanni sissevooluga (vt lk 60)

## Sümbolite kirjeldus

**X**

Vanni keskoht / Dušivanni kese

**Y**

Mõõt Y = vooliku seinaväljavoolu keskmest vannitüüri keskele jagatud 2-ga (võimalusel kohandage keraamiliste plaatide asetusega).



Soe vesi



Külm vesi



Alates • on funktsioneerimine garanteeritud



Selles alas tuleb seina tugevdada.



Võimalik on ainult üks funktsioon, mitte kaks korraga.



% Paigaldage kehaduši jaoks vajalikud veetorud kaldega.



Loputusplokk kpl. #15956000



peiteklapp



Quattro-liitmik



Katkestus- ja ümberlülitusklapp Trio Universal



Vanni kraan



Mittevajalik väljavool tuleb sulgeda korgiga. (DN20, 3/4")



Äravoolu jõudlus peab olema suurem kui 50 l/min.



Äravool



iBox ühenduses ära- ja ülevoolugarnituuriga Exafilli vanni sissevooluga

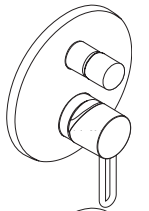

62, 72,  
74

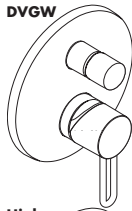

DVGW

60

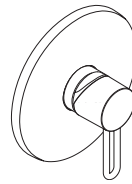

64 - 68,  
82

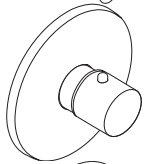

76, 80,  
84

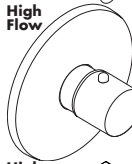

High  
Flow

86 - 90,  
94, 96,  
102 - 112

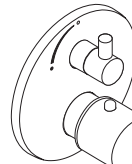

64 - 68,  
82

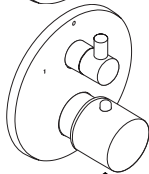

62, 72,  
74, 78

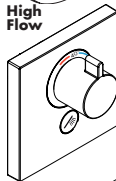

High  
Flow

92, 98,  
100, 114

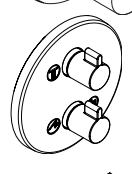

102

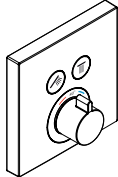

62, 72,  
74, 78

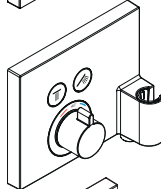

70

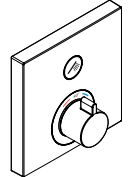

64 - 68

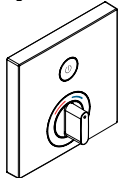

64 - 68

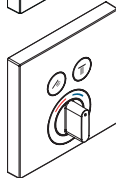

62, 72,  
74, 78

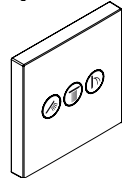

92,  
98 - 102,  
110 - 114

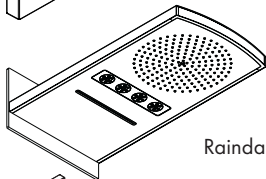

92, 94

Raindance Rainfall 240

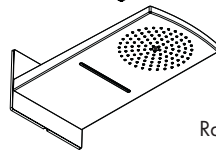

106 - 110

Raindance Rainfall 180

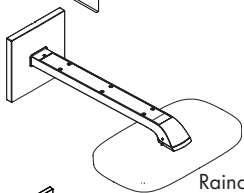

100

Raindance Select E 300

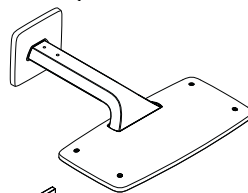

102, 104

Raindance E 420

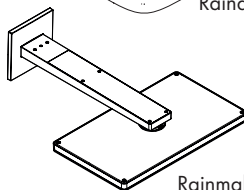

112

Rainmaker Select 460 2jet

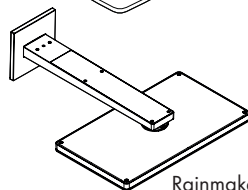

114

Rainmaker Select 460 3jet



- Uzstādīšanas piemēri ar izmēriem un vadu izkārtojumu atrodami, sākot no 60 lappuses.
- Montāžas instrukcijās dotie montāžas izmēri ir ideāli piemēroti personām, kuru augums ir apm. 1800 mm. Nepieciešamības gadījumā šie izmēri ir jāpielāgo. Šeit ir jāņem vērā, ka mainoties montāžas augstumam, mainās arī minimālais augstums, un jāņem vērā arī pieslēgšanas izmēru izmaiņas.
- Patēriņš ir noteikts praktiski ar atbilstošu armatūru (termostats/maisītājs/zemapmetuma vārsts).
- iBox kombinācijā ar Exafill vannas ieplūdi ar noplūdes un pārplūdes garnitūru (skat. lpp. 60)

## Simbolu nozīme



Vannas vidus / Dušas paliktna vidus



Izmērs Y = šļūtenes savienojuma loka vidu līdz vannas ietece vidum dalīt ar 2 (eventuāli piemērot flīžu rakstam)



Siltais ūdens



Aukstais ūdens



No • funkcija nodrošināta



Šajā zonā ir nepieciešams pastiprināt sienu.



Iespējams tikai viens patērētājs, nedrīkst vienlaikus būt divi patērētāji.



Montēt ūdens cauruļvadus sānu (ķermeņa) dušām ar atbilstošu slīpumu.



Skalošanas bloks, kompl. #15956000



Zemapmetuma ventilis



Četrvirzienu pārslēgs



Trīsvirzienu universālais noslēgvārsts un pārslēdzējvārsts



Vannas tekne



Neizmantoto izteku aizbāzt ar aizbāzni. (DN20, 3/4")



Notece veikspējai jābūt vairāk nekā 50 l/min.



Notece



iBox kombinācijā ar Exafill vannas ieplūdi ar noplūdes un pārplūdes garnitūru

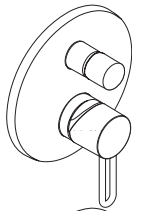

62, 72,  
74

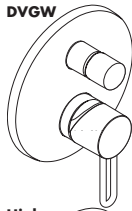

DVGW

60

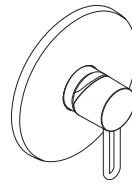

64 - 68,  
82

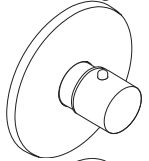

76, 80,  
84

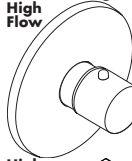

High  
Flow

86 - 90,  
94, 96,  
102 - 112

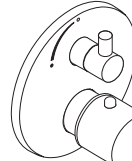

64 - 68,  
82

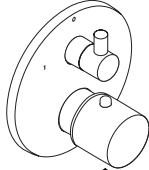

62, 72,  
74, 78

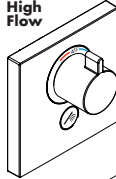

High  
Flow

92, 98,  
100, 114

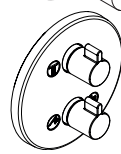

102

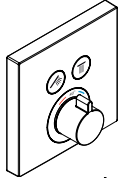

62, 72,  
74, 78

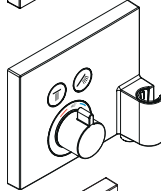

70

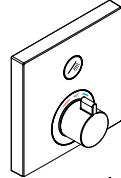

64 - 68

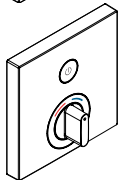

64 - 68

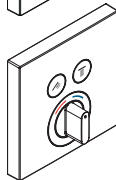

62, 72,  
74, 78

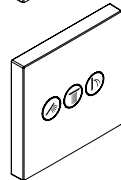

92,  
98 - 102,  
110 - 114

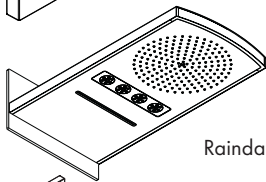

92, 94

Raindance Rainfall 240

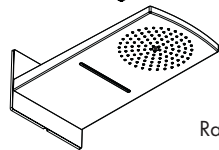

106 - 110

Raindance Rainfall 180

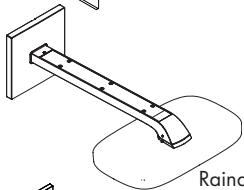

100

Raindance Select E 300

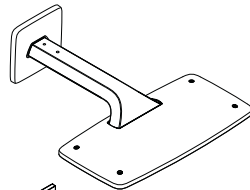

102, 104

Raindance E 420

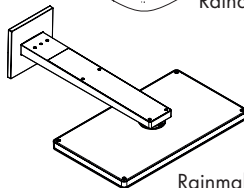

112

Rainmaker Select 460 2jet

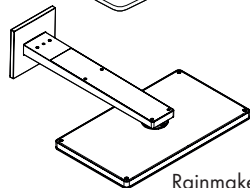

114

Rainmaker Select 460 3jet



- Primeri instalacija sa veličinama i dimenzijama vodova mogu se naći od stranice 60 nadalje.
- Montažne dimenzije navedene u uputstvu za montažu idealne su za osobe visine oko 1800 mm, tako da se po potrebi moraju prilagoditi konkretnoj visini korisnika. Pri tome treba uzeti u obzir da se prilikom promene montažne visine menja i minimalna visina kao i da se u tom slučaju mora uvažiti i promena priključnih dimenzija.
- Vrednosti potrošnje su u praksi merene sa pripadajućim armaturama (termostat/mešač/uzidni ventil).
- iBox u kombinaciji sa Exafill dotokom kade sa odvodnom i prelivnom garniturom (vidi stranu 60)

## Opis simbola

**X**

Sredina kade / Sredina tuš-kada

**Y**

Mera Y = sredina priključnog luka creva do sredine dotoka kade podeljeno sa 2 (eventualno prilagoditi rasteru pločica).



Topla voda



Hladna voda



Od • je funkcija zagarantovana.



U ovoj oblasti je potrebno ojačanje zida.



Moguće je koristiti samo jedan potrošač, nikako dva istovremeno!



% Položite vodovodne cevi za bočni tuš s nagibom.



kompletan blok #15956000



Uzidni ventil



Quattro četverostruki preusmerivač



Trio Universal ventil za zatvaranje i preklopni ventil



Dotok kade



Izlaz koji se ne koristi, mora se zatvoriti slepim čepom. (DN20, 3/4")



Kapacitet odvoda mora biti veći od 50 l/min.



Ispust



iBox u kombinaciji sa Exafill dotokom kade sa odvodnom i prelivnom garniturom



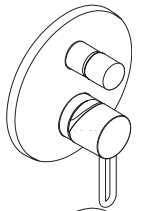

62, 72,  
74

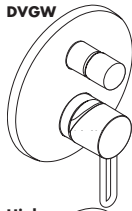

DVGW

60

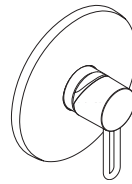

64 - 68,  
82

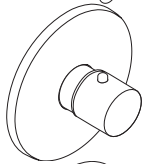

76, 80,  
84

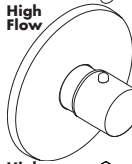

High  
Flow

86 - 90,  
94, 96,  
102 - 112

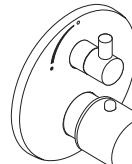

64 - 68,  
82

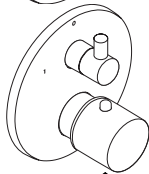

62, 72,  
74, 78

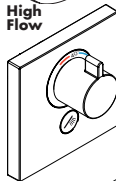

High  
Flow

92, 98,  
100, 114

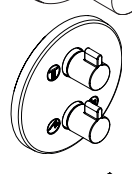

102

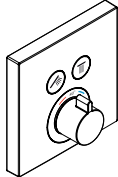

62, 72,  
74, 78

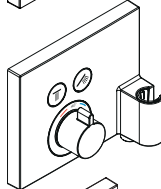

70

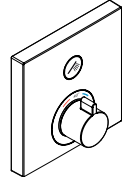

64 - 68

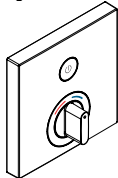

64 - 68

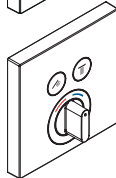

62, 72,  
74, 78

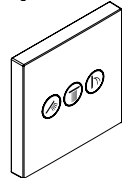

92,  
98 - 102,  
110 - 114

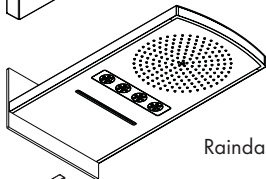

92, 94

Raindance Rainfall 240

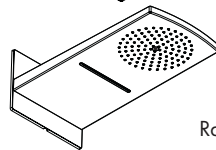

106 - 110

Raindance Rainfall 180

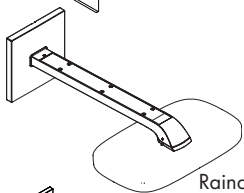

100

Raindance Select E 300

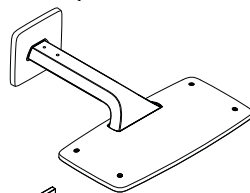

102, 104

Raindance E 420

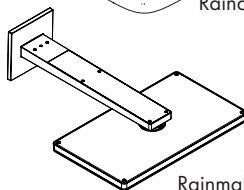

112

Rainmaker Select 460 2jet

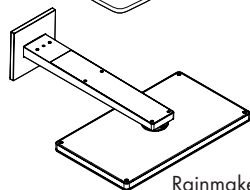

114

Rainmaker Select 460 3jet



- Installasjonseksempel med målangivelser og ledningsdimensjoner finns fom. side 60.
- Monteringsmål i monteringsveiledningen er beregnet for personer som er omtrent 1800 mm høye, målene skal eventuell tilpasses om nødvendig. Her skal man passe på at ved endrede monteringsmålene blir minstehøyden endret, og det må tas hensyn til de endrede tilkoblingsmålene.
- Forbruksverdiene måles ved normal bruk med tilhørende armatur (temostat/blandebatteri/innmurt ventil).
- iBox i kombinasjon med Exfill karinnløp med avløps- og overflytgarnityr (se side 60)

## Symbolbeskrivelse

**X**

Midten av badekaret / Midten på dusjkar

**Y**

Mål Y = Midten til slangetilkoblingsbue t.o.m. badekarinnløp delt på 2 (eventuelt skal fliseraster tilpasses).



Varmtvann



Kaldtvann



F.o.m. • er funksjonen garantert



I dette området skal veggen forsterkes.



Kun en forbruker mulig, ikke to samtidig.



Vannledninger for sidedusjer installeres med fall.



Spyleblokk kpl. #15956000



Innfelt ventil



Quattro fire-veis omstilling



Trio universal stenge- og omstillingsventil



Innløp badekar



Utgangen som ikke brukes kan tettes med en blindplugg. (DN20, 3/4")



Avløp ytelse skal være mer enn 50 l/min.



Avløp



iBox i kombinasjon med Exfill karinnløp med avløps- og overflytgarnityr

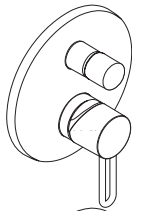

62, 72,  
74

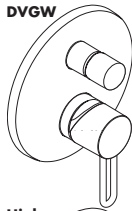

DVGW

60

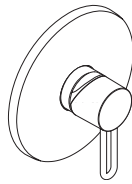

64 - 68,  
82

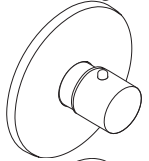

76, 80,  
84

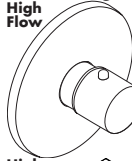

High  
Flow

86 - 90,  
94, 96,  
102 - 112

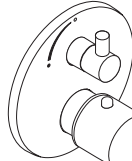

64 - 68,  
82

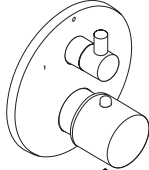

62, 72,  
74, 78

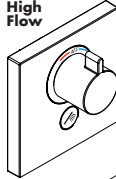

High  
Flow

92, 98,  
100, 114

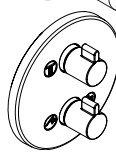

102

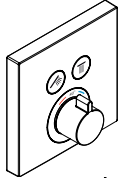

62, 72,  
74, 78

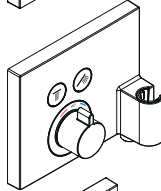

70

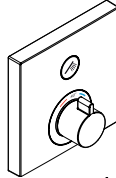

64 - 68

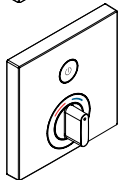

64 - 68

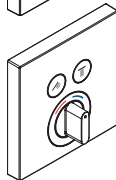

62, 72,  
74, 78

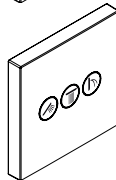

92,  
98 - 102,  
110 - 114

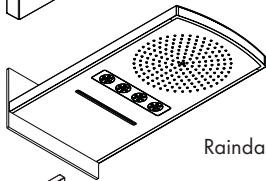

92, 94

Raindance Rainfall 240

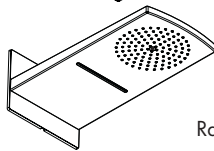

106 - 110

Raindance Rainfall 180

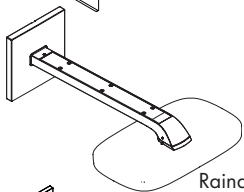

100

Raindance Select E 300

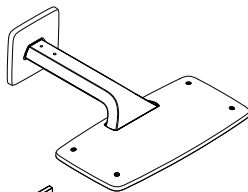

102, 104

Raindance E 420

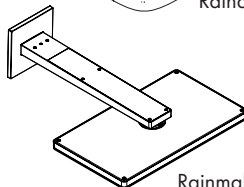

112

Rainmaker Select 460 2jet

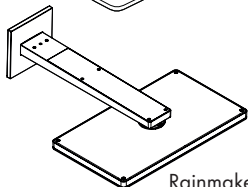

114

Rainmaker Select 460 3jet



- Примери за инсталация с данни за размери и определяне на размерите на тръбопроводите можете да намерите от стр. 60 нататък.
- Посочените в ръководството за монтаж монтажни мерки са идеални за лица с ръст от прибл. 1800 мм и трябва съответно да се пригодят. При това обърнете внимание на това, при променена монтажна височина се променя минималната височина и трябва да бъде взета под внимание промяната на присъединителните размери.
- Стойностите за разхода бяха измерени във връзка с практиката със съответните арматури (термостат/смесител/клапан за полагане в мазилката).
- iVox в комбинация с вход за вана Exafill с гарнитура за изтичане и преливане.  
(вижте стр. 60)



Мощността на изтичане трябва да бъде повече от 50 л/мин.



Отвеждане

iVox в комбинация с вход за вана Exafill с гарнитура за изтичане и преливане.

## Описание на символите

**X** Среда на ваната / Среда на коритото на душ-кабината

**Y** Мярка Y = Среда на присъединителното коляно на маркуча до входа на ваната разделено на 2 (евентуално изравнете към растера на плочките).



Топла вода



Студена вода



От • функцията е гарантирана.



В тази област е необходимо подсилване на стената.



Възможен е само един консуматор, не два едновременно.



% Водопроводните линии за страничните разпръскватели полагайте с наклон.



Изплаквач блок компл. #15956000



Клапан за мазилка



Четирипътно превключване Quattro



Спирателен и превключващ клапан Trio Universal



Вход за вана



Излишният извод може да се уплътни с глуха пробка. (DN20, 3/4")

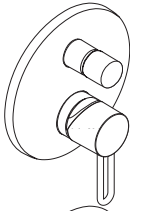

62, 72,  
74

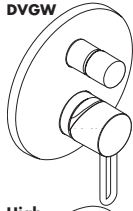

DVGW

60

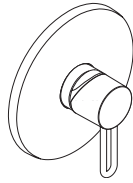

64 - 68,  
82

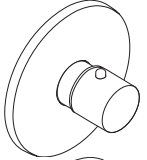

76, 80,  
84

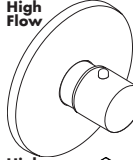

High  
Flow

86 - 90,  
94, 96,  
102 - 112

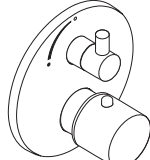

64 - 68,  
82

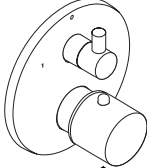

62, 72,  
74, 78

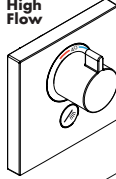

High  
Flow

92, 98,  
100, 114

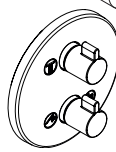

102

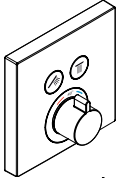

62, 72,  
74, 78

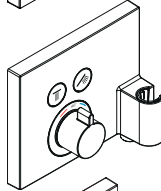

70

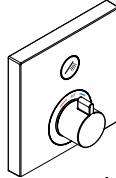

64 - 68

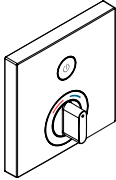

64 - 68

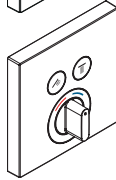

62, 72,  
74, 78

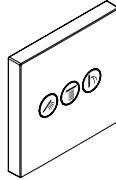

92, 98 - 102,  
110 - 114

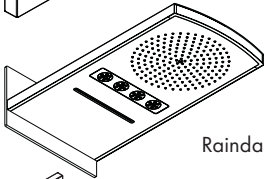

92, 94

Raindance Rainfall 240

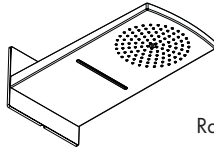

106 - 110

Raindance Rainfall 180

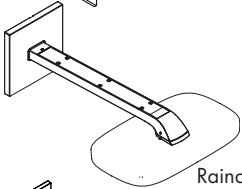

100

Raindance Select E 300

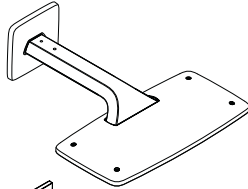

102, 104

Raindance E 420

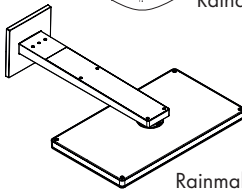

112

Rainmaker Select 460 2jet

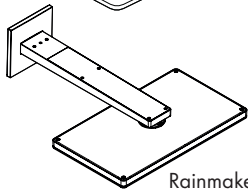

114

Rainmaker Select 460 3jet



iBox-i në kombinim me në garniturë dalëse dhe rrjedhëse Exafill hyrjen e vaskës

- Shembujt e instalimit me përmasat dhe dimensionimet e tubacioneve mund t'i gjeni nga faqja 60.
- Përmasat e montimit të cekura në udhëzimin teknik të montimit janë ideale për persona me gjatësi afro 1800 mm (180 cm) dhe eventualisht duhen përshtatur. Këtu duhet pasur parasysh që me ndryshimin e lartësisë së montimit, ndryshon edhe lartësia e cekur minimale si dhe ndryshimi i përmasave të lidhjeve.
- Vlerat e konsumit janë matur praktikisht me pajisje përkatëse të valvulave/pajisjeve të ujit (termostati / miksuksi / ventili nën sipërfaqës suvuar).
- iBox-i në kombinim me në garniturë dalëse dhe rrjedhëse Exafill hyrjen e vaskës (shih faqen 60)

## Përshkrimi i simbolit

**X**

Mesi i vaskës / Mesi i vaskës së dushit

**Y**

Përmasa Y = mesi i harkut të lidhjes së zorrës deri tek mesi i hyrjes së vaskës pjesëtim për 2 (eventualisht i duhet përshtatur këndit të pllakave të murit).



Uji i ngrohtë



Uji i ftohtë



Nga • është i mundur funksioni.



Në këtë zonë është i nevojshëm një përforsim i murit.



Ekziston mundësia vetëm për një konsumator, jo për dy njëkohësisht.



Vendosni tubacionet e ujit për spërkatëset anësore me pjerrësi.



Bloku shpëlarës komplet #15956000



Ventili i suvajës



Valvul devijuese Quattro me katër drejtime



Valvul universale Trio për bllokim dhe devijim



Vrima për mbushjen e vaskës



Dalja që nuk nevojitet duhet izoluar me tapë qorre. (DN20, 3/4")



Kapaciteti i shkarkimit duhet të jetë më shumë se 50 l/minutë.



Shkarkimi

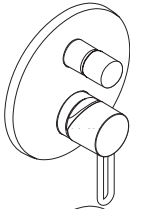

62, 72,  
74

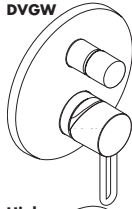

**DVGW**

60

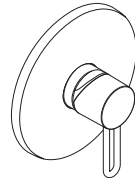

64 - 68,  
82

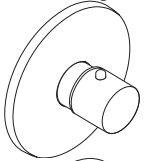

76, 80,  
84

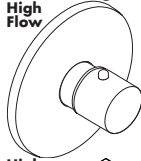

**High Flow**

86 - 90,  
94, 96,  
102 - 112

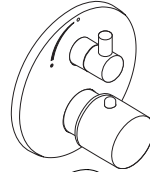

64 - 68,  
82

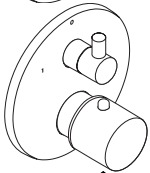

62, 72,  
74, 78

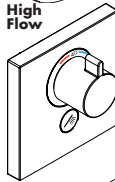

**High Flow**

92, 98,  
100, 114

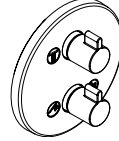

102

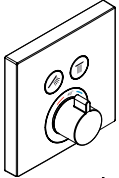

62, 72,  
74, 78

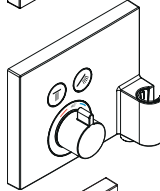

70

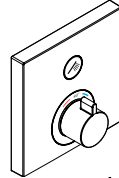

64 - 68

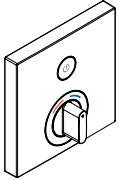

64 - 68

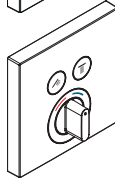

62, 72,  
74, 78

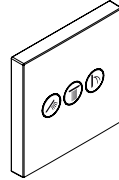

92,  
98 - 102,  
110 - 114

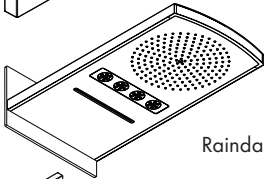

92, 94

Raindance Rainfall 240

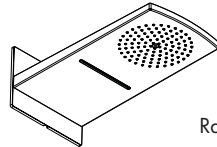

106 - 110

Raindance Rainfall 180

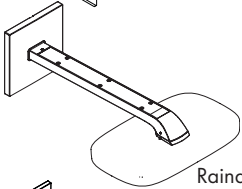

100

Raindance Select E 300

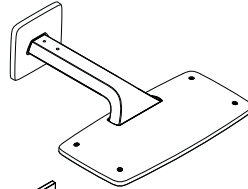

102, 104

Raindance E 420

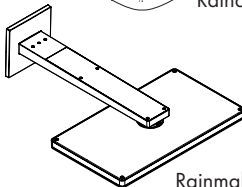

112

Rainmaker Select 460 2jet

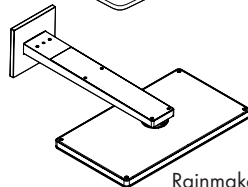

114

Rainmaker Select 460 3jet



- يوجد بدءاً من صفحة 60 أمثلة للتركيب بمقاسات وطرق عمل بعض الوصلات.
- تعد أبعاد التركيب الواردة في إرشادات التركيب هذه مثالية بالنسبة للأشخاص الذين يبلغ طولهم حوالي 1800 مم ويمكن تغيير الأبعاد عند الحاجة. وبالتالي سينغير الحد الأدنى للارتفاع في حالة تغيير ارتفاع التركيب، مما يعني الأخذ في الاعتبار تغيير أبعاد التوصيل.
- تم قياس قيم الاستهلاك طبقاً للخبرة العملية في استعمال خلطات المياه الخاصة بذلك (ترموسنات/خلط/صمام تحت الملاط).
- وحدة "iBox" مع وحدة التدفق بالحوض من النوع "Exafill" مع لوازم تصريف الماء وتصريف تدفق المياه. (راجع صفحة 60)

### وصف الرمز

منتصف حوض الاستحمام / بانينو مزود بدش  
في المنتصف **X**

البعد  $\gamma$  = مركز مرفق مخرج حائط الخرطوم  
إلى مركز حشوة الحمام مقسوماً على 2 (مطابق  
لشكل البلاطة إن أمكن). **Y**

ماء دافئ 

ماء بارد 

من • الوظيفة مضمونة. 

يلزم هذا في النطاق وجود تقوية للحائط. 

لا يمكن القيام بأكثر من وظيفة واحدة. 

قم بتركيب مواسير المياه للدش العادي المنحدر. 

قارنة وحدة الغسل #15956000 

صمام التدفق 

تغيير مسار رباعي كواترو 

صمام حجز وتغيير تريبو يونيفرسال 

مدخل مياه للبانينو 

قم بسد المنفذ غير المستخدم. (DN20, 3/4") 

يجب أن تكون قدرة الصرف أكبر من 50 لتر/دقيقة 

تصريف 

وحدة "iBox" مع وحدة التدفق بالحوض من النوع "Exafill" مع لوازم تصريف الماء وتصريف تدفق المياه. 



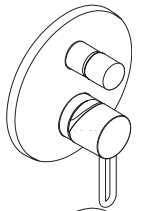

62, 72,  
74

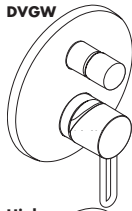

DVGW

60

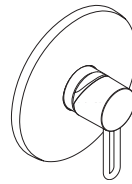

64 - 68,  
82

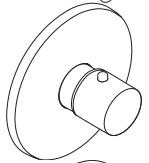

76, 80,  
84

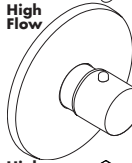

High  
Flow

86 - 90,  
94, 96,  
102 - 112

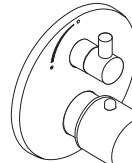

64 - 68,  
82

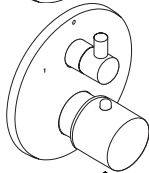

62, 72,  
74, 78

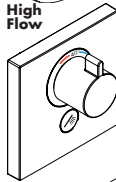

High  
Flow

92, 98,  
100, 114

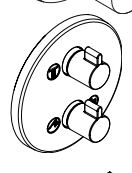

102

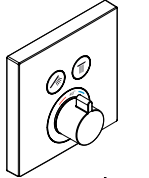

62, 72,  
74, 78

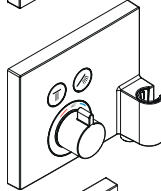

70

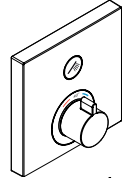

64 - 68

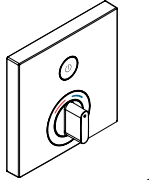

64 - 68

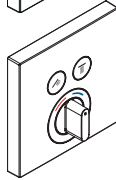

62, 72,  
74, 78

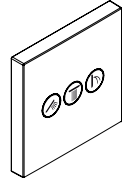

92,  
98 - 102,  
110 - 114

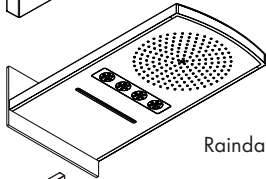

92, 94

Raindance Rainfall 240

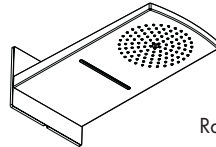

106 - 110

Raindance Rainfall 180

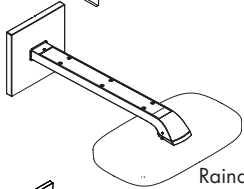

100

Raindance Select E 300

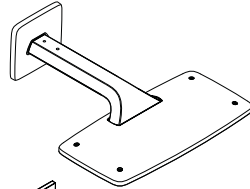

102, 104

Raindance E 420

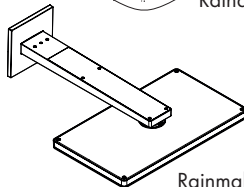

112

Rainmaker Select 460 2jet

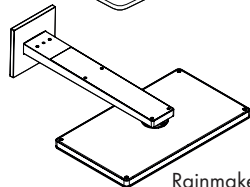

114

Rainmaker Select 460 3jet



- Felszerelési példák méretekkel és vezeték- dimenzió- nálással az 60 oldaltól kezdődően találhatóak.
- A szerelési útmutatóban megadott szerelési méretek kb. 1800 mm testmagasságú személyeknek alkalmasak, és ennek megfelelően átméretezendők. Itt arra kell ügyelni, hogy az átméretezett szerelési magasságnál megváltozik a minimális magasság és figyelembe kell venni a csatlakozó méreteinek változását.
- A fogyasztási értékeket, a gyakorlathoz közel álló módon, a hozzátartozó csaptelepekkel (termosztát/ keverő csaptelep/vakolat alatti szelep) mértük.
- iBox, valamint Exafill kádtöltő, le- és túlfogyó kombinációja (lásd a oldalon 60)



iBox, valamint Exafill kádtöltő, le- és túlfogyó kombinációja

## Szimbólumok leírása

**X**

A kád közepe / Zuhanytálca közepe

**Y**

Y méret = a csőcsatlakozó közepétől a kádtöltő befolyócső közepéig, osztva kettővel (szükség esetén a csempe kiosztásához igazítva).



Melegvíz



Hidegvíz



A • -től működik az adott funkció.



Ezen a területen a fal megerősítésére van szükség.



Egyidejűleg csak egy fogyasztót lehet használni, két fogyasztó (zuhanyrózsa, oldalzuhanyok) egyszerre nem tud működni.



% Az oldalzuhanyokhoz a vízvezeték lejtéssel ajánlott beszerezni.



Öblítőblokk csatlakozó #15956000



Falsík alatti szelep



Quattro négy-utas átalakító



Trio univerzális záró- és váltószelep



Kádbevezetés



A fölösleges kimenetet vakdugóval kell lezárni. (DN20, 3/4")



A lefolyó teljesítményének 50l/percnél magasabbnak kell lenni



Lefolyó

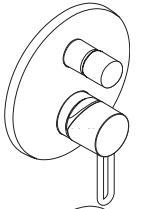

62, 72,  
74

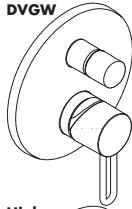

DVGW

60

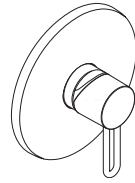

64 - 68,  
82

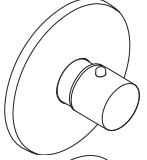

76, 80,  
84

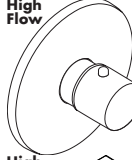

High Flow

86 - 90,  
94, 96,  
102 - 112

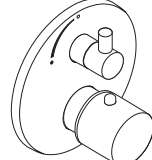

64 - 68,  
82

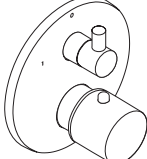

62, 72,  
74, 78

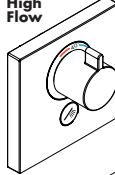

High Flow

92, 98,  
100, 114

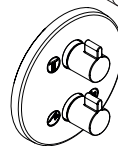

102

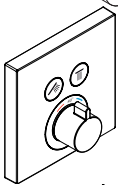

62, 72,  
74, 78

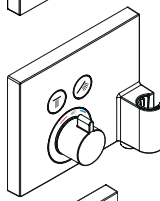

70

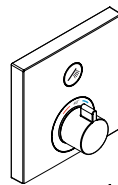

64 - 68

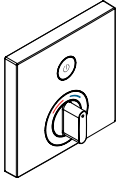

64 - 68

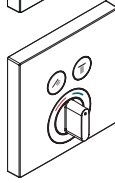

62, 72,  
74, 78

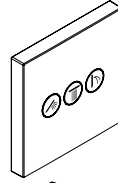

92, 98 - 102,  
110 - 114

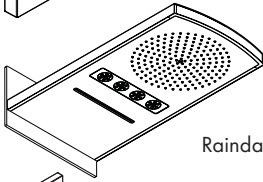

92, 94

Raindance Rainfall 240

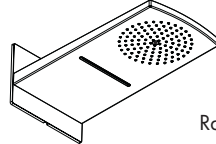

106 - 110

Raindance Rainfall 180

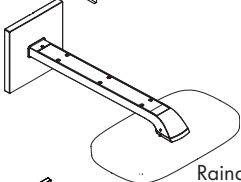

100

Raindance Select E 300

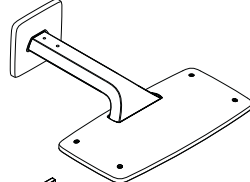

102, 104

Raindance E 420

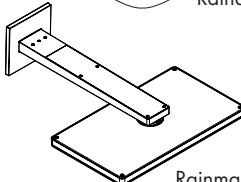

112

Rainmaker Select 460 2jet

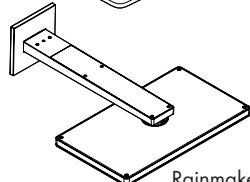

114

Rainmaker Select 460 3jet

DVGW

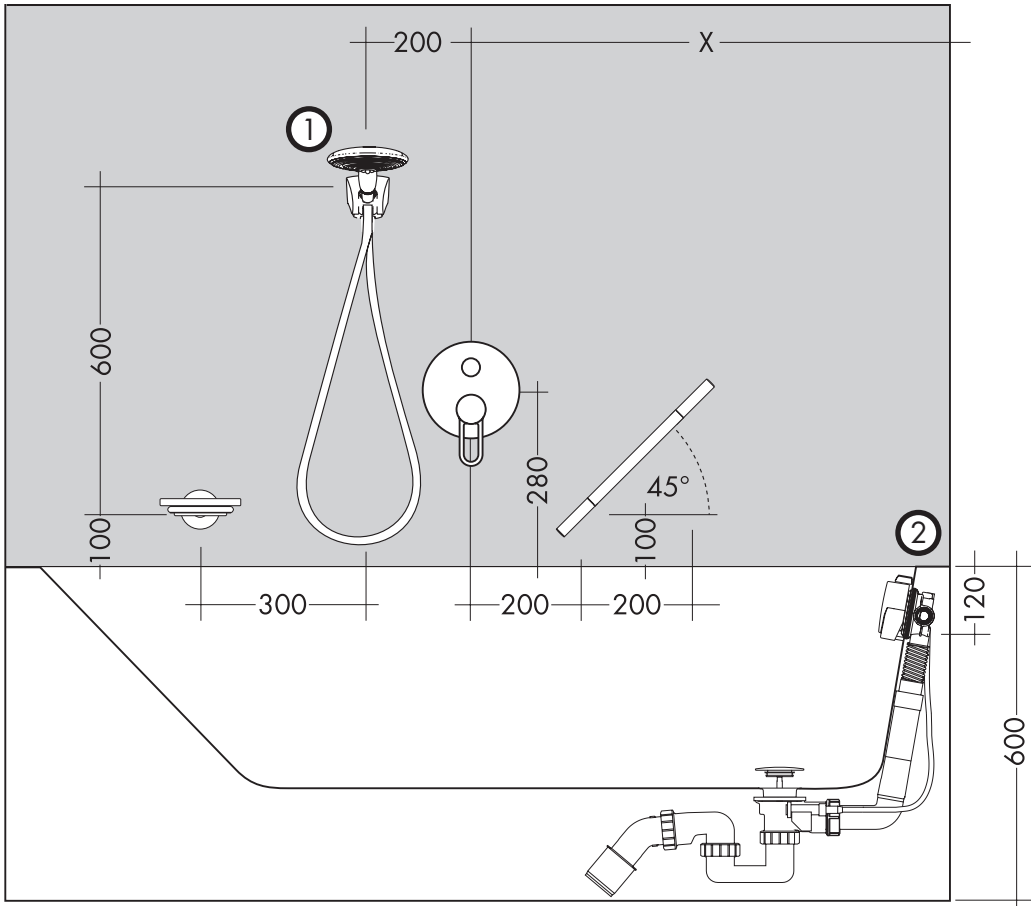
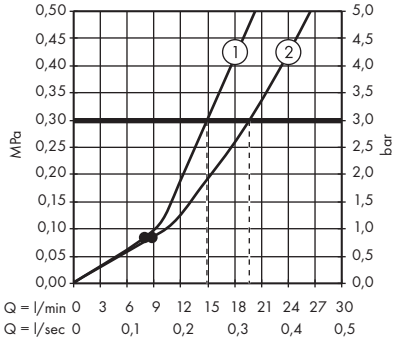
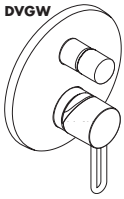

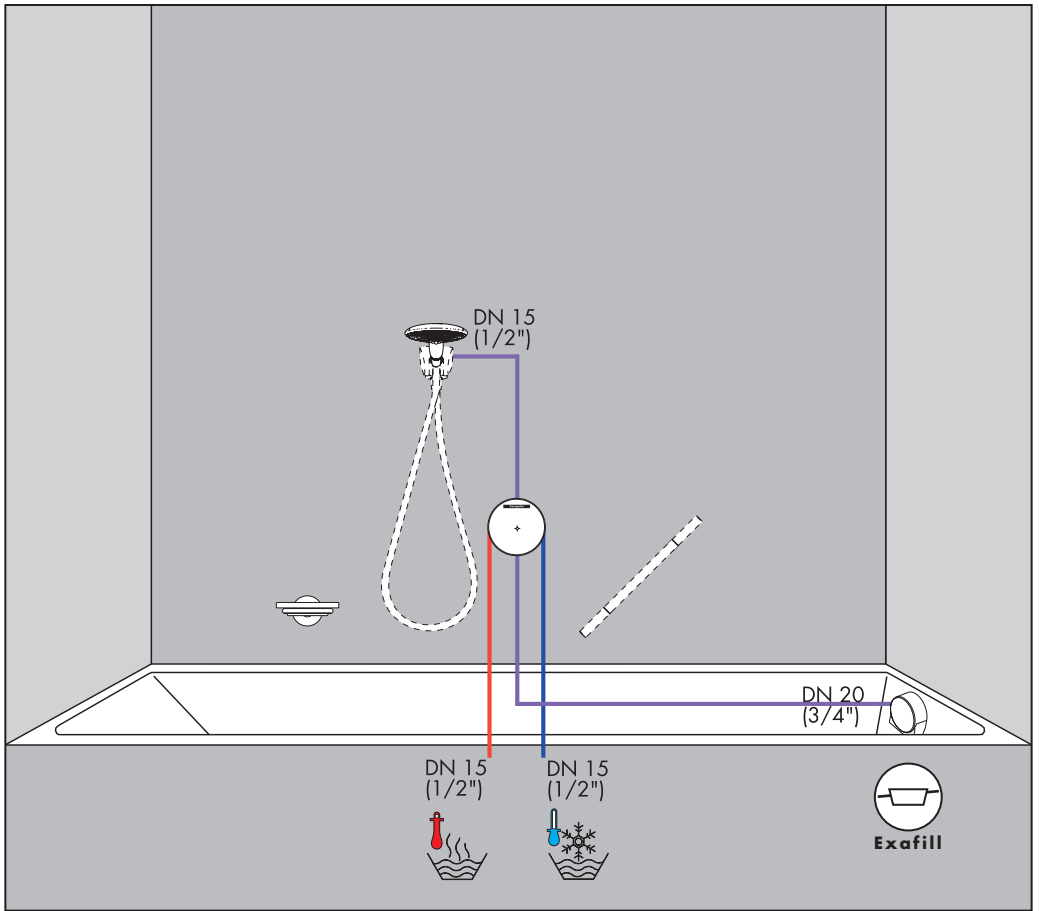





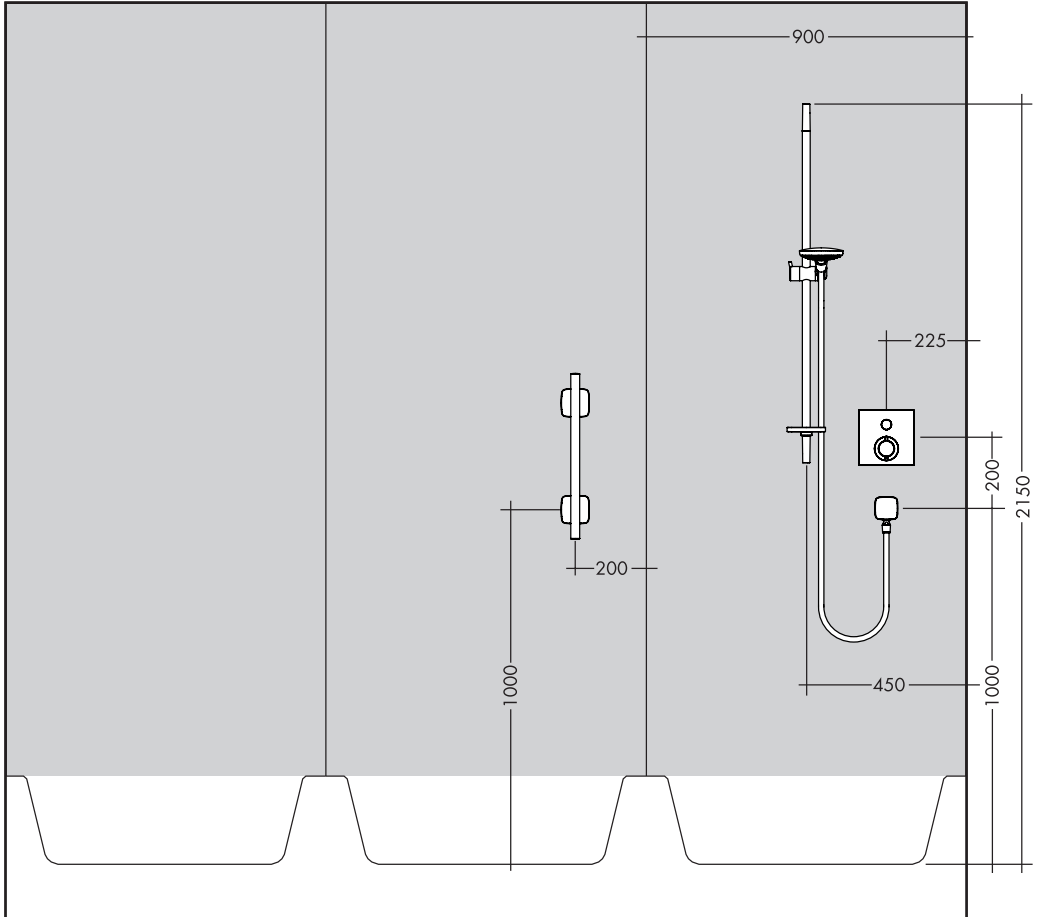
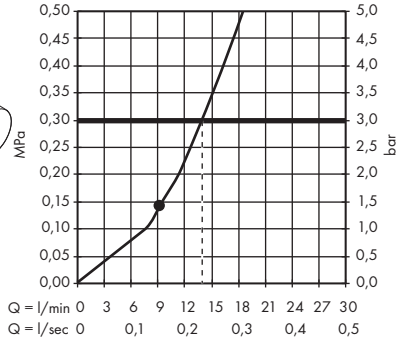
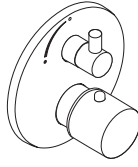
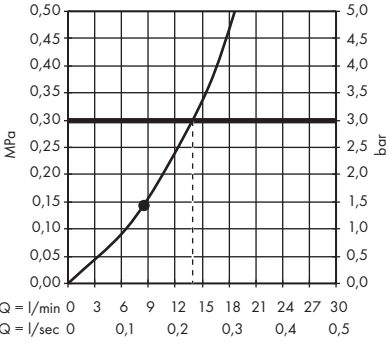
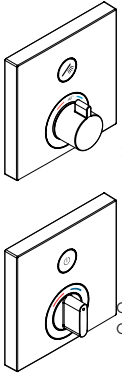



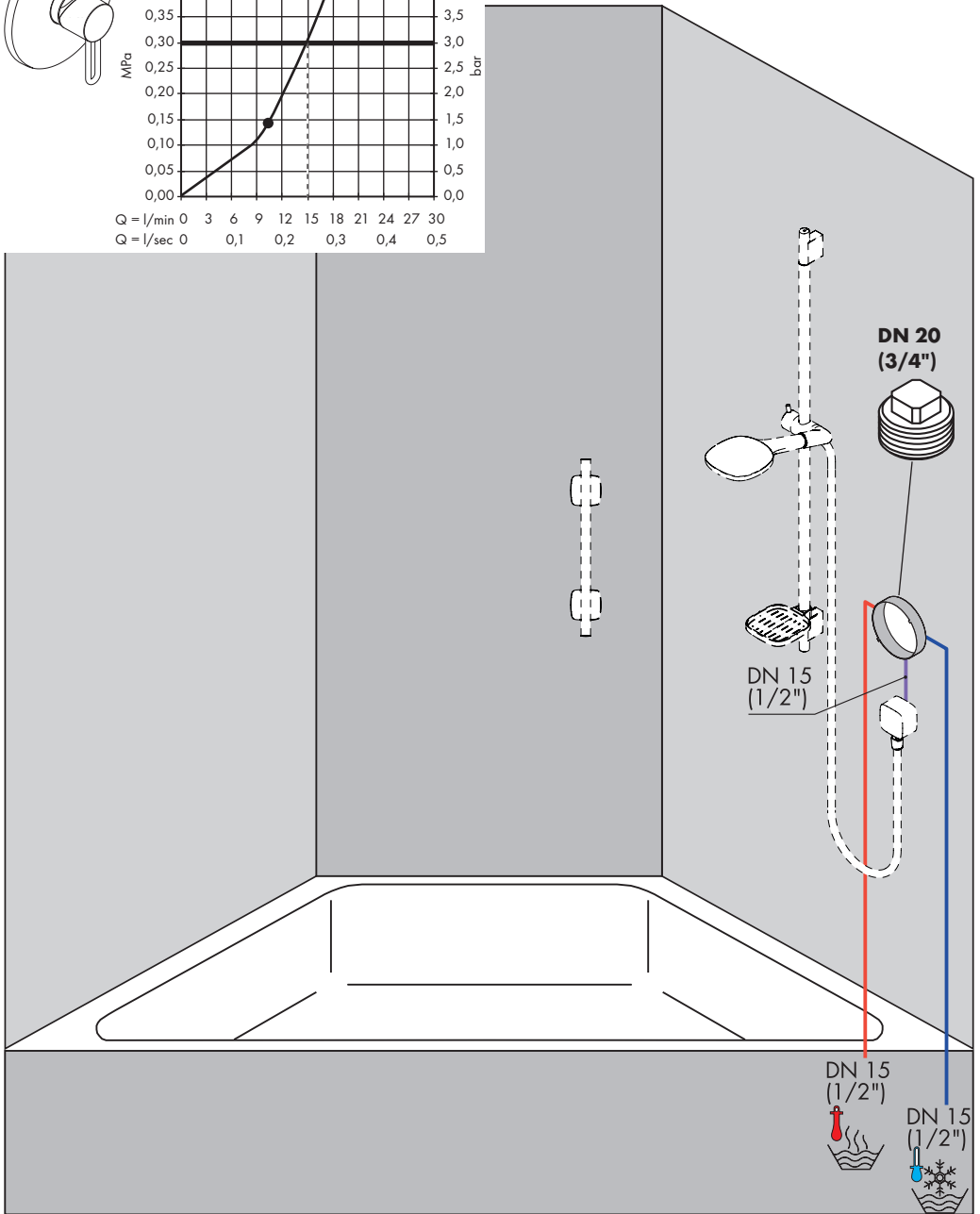
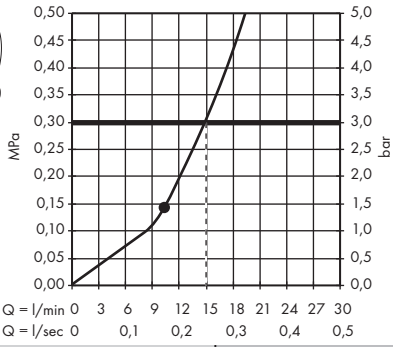
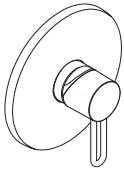

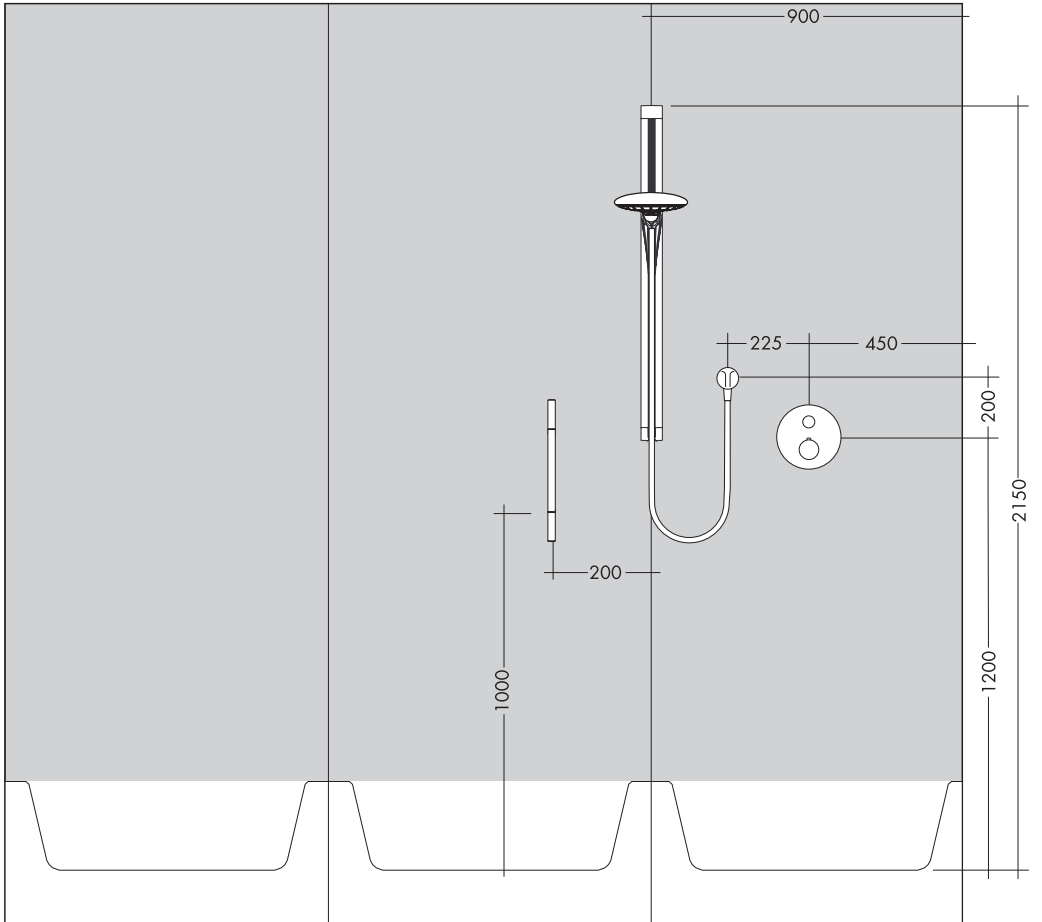
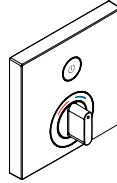
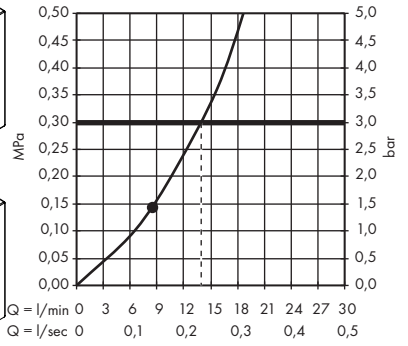
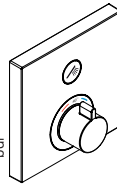
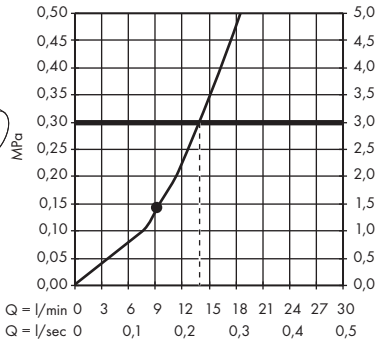
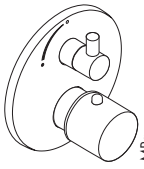

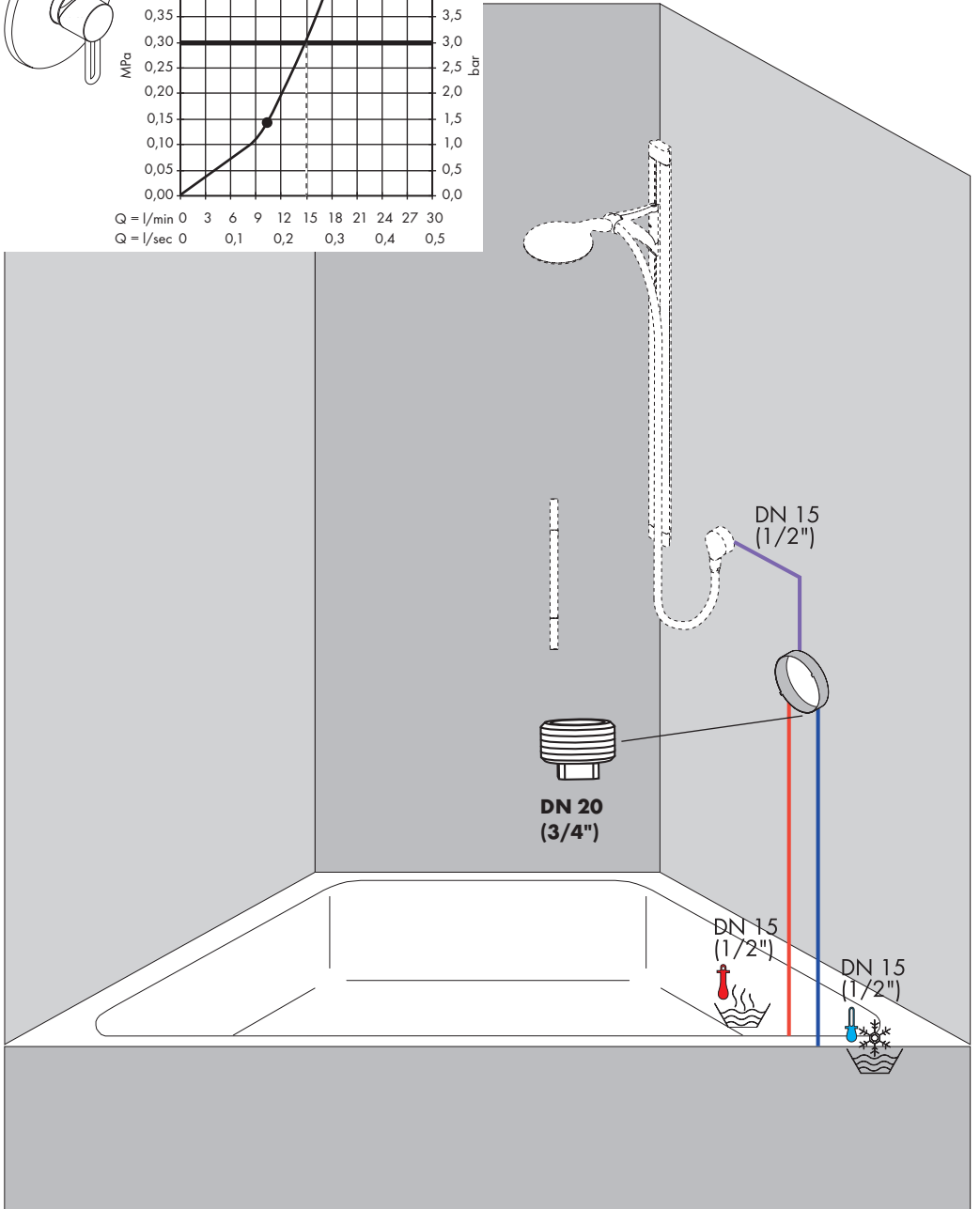
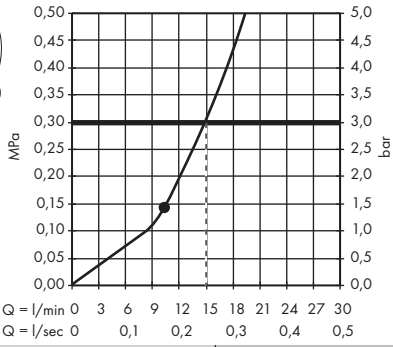
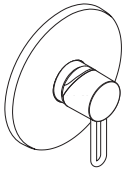

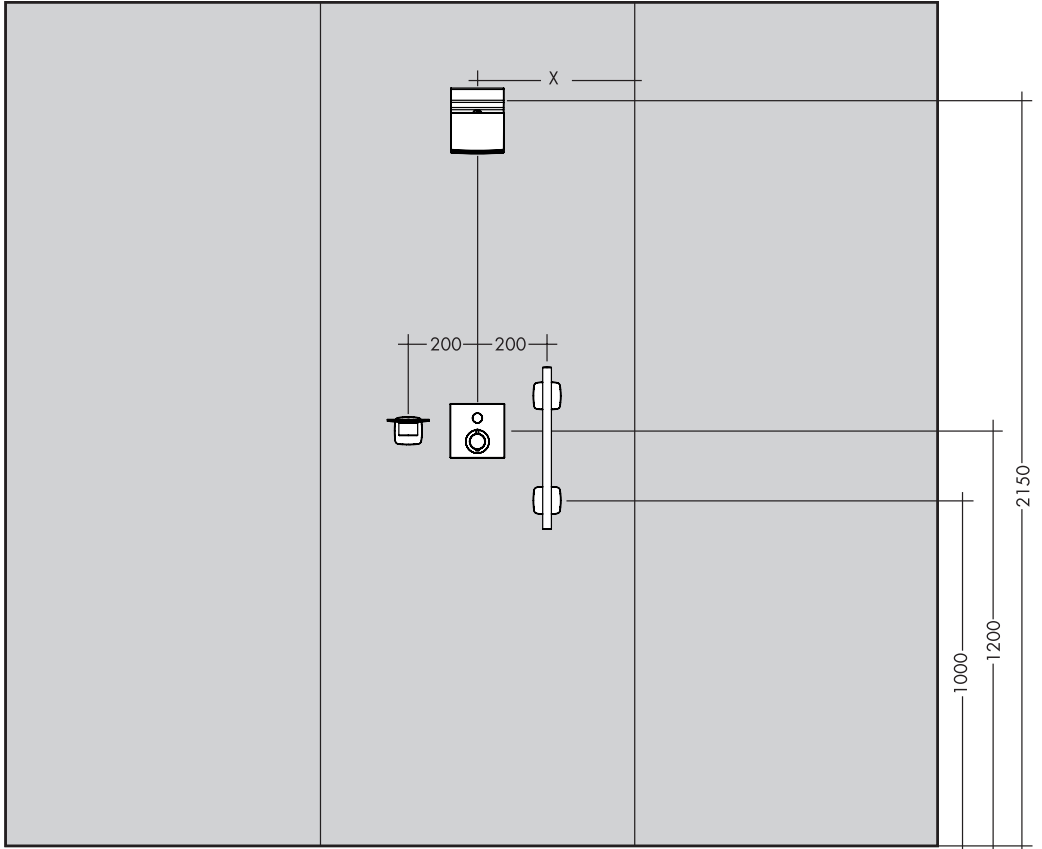
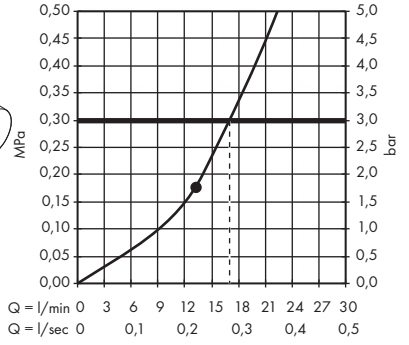
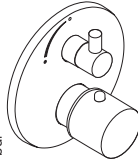
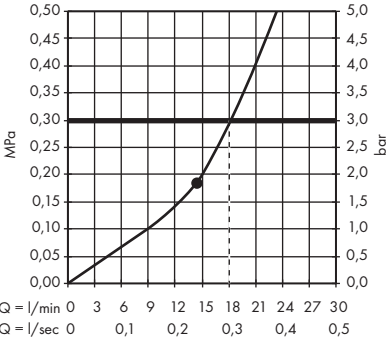
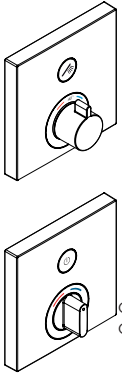

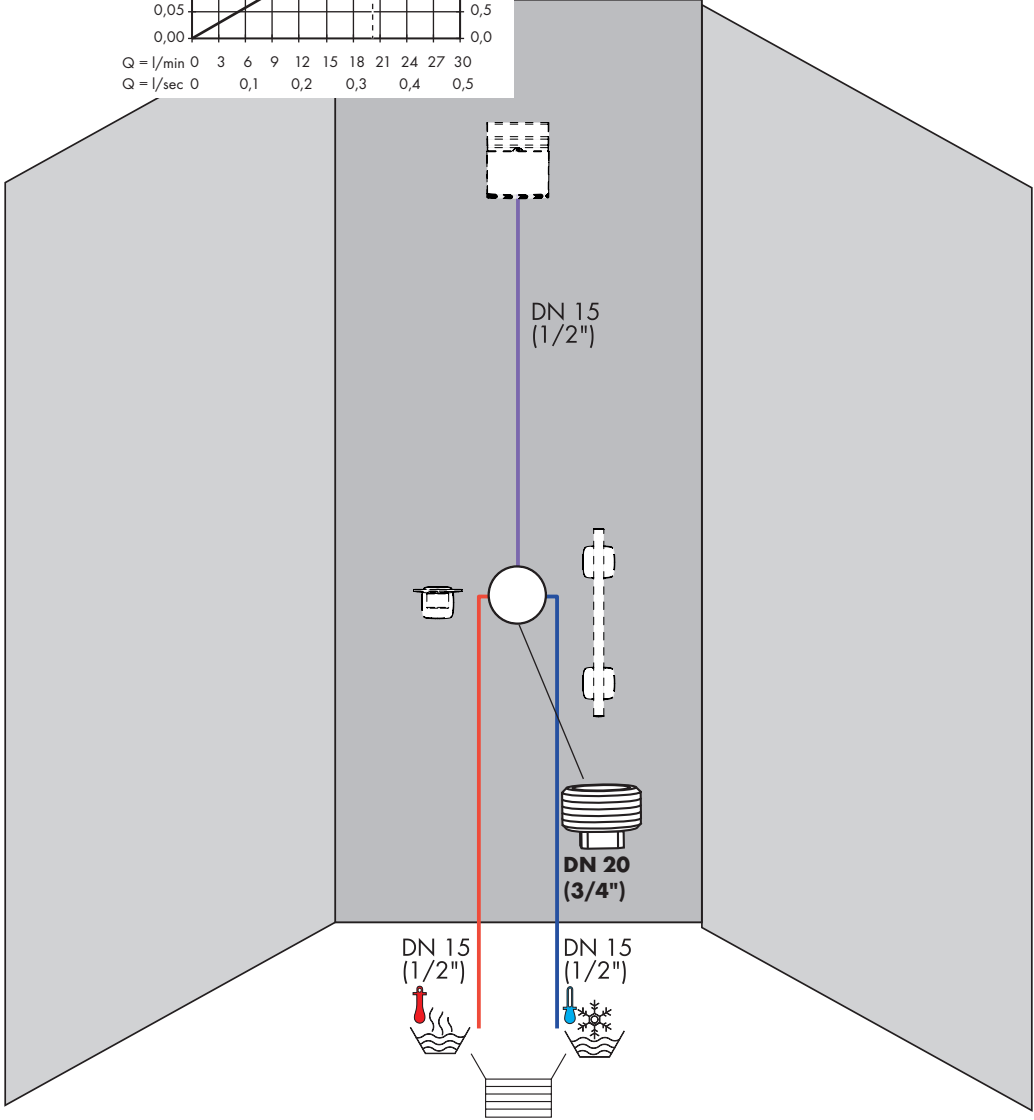
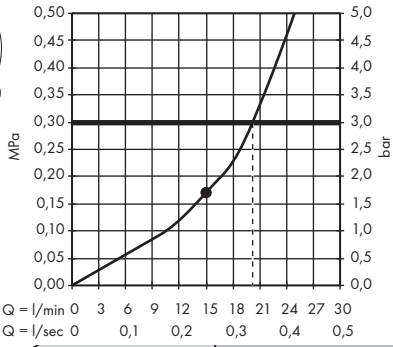
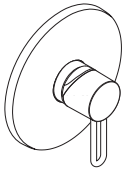

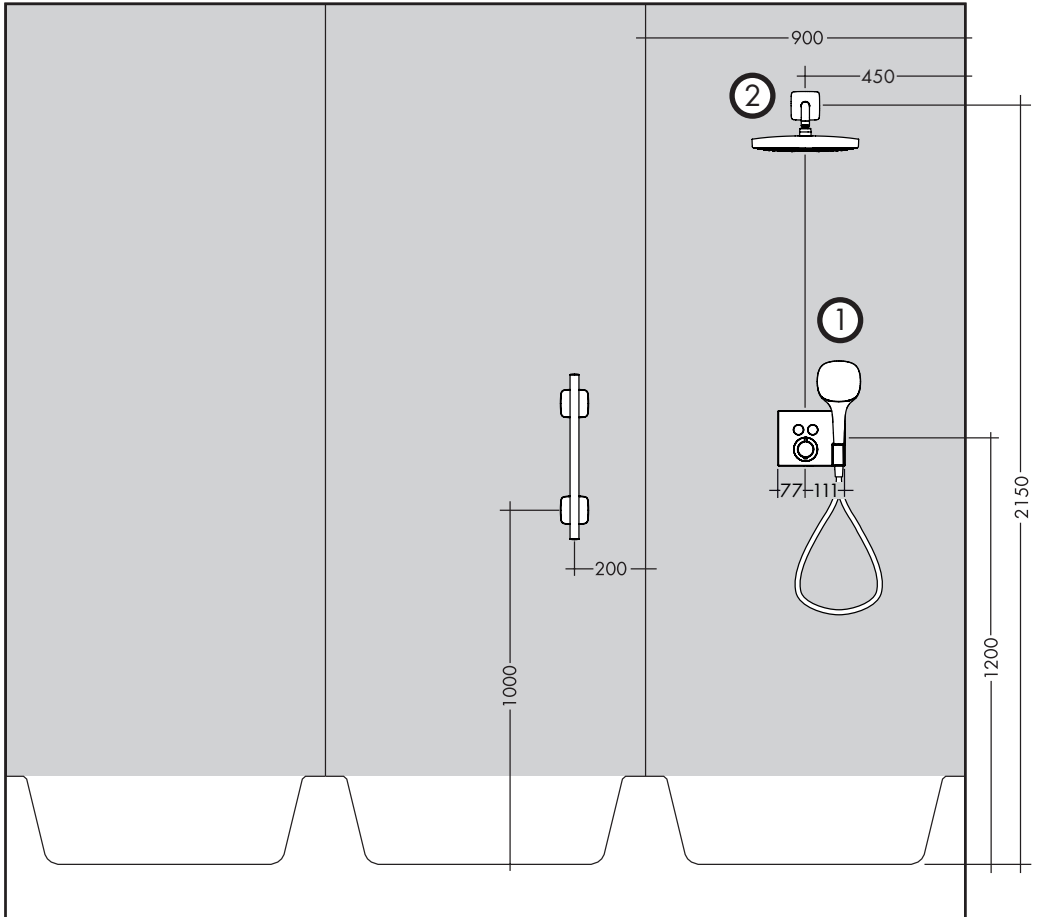
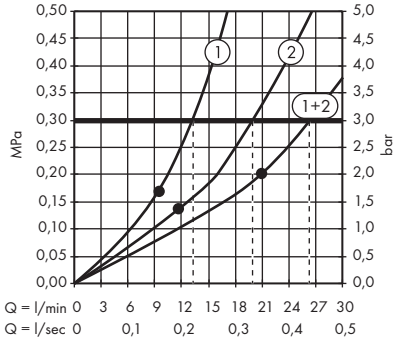
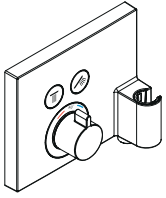

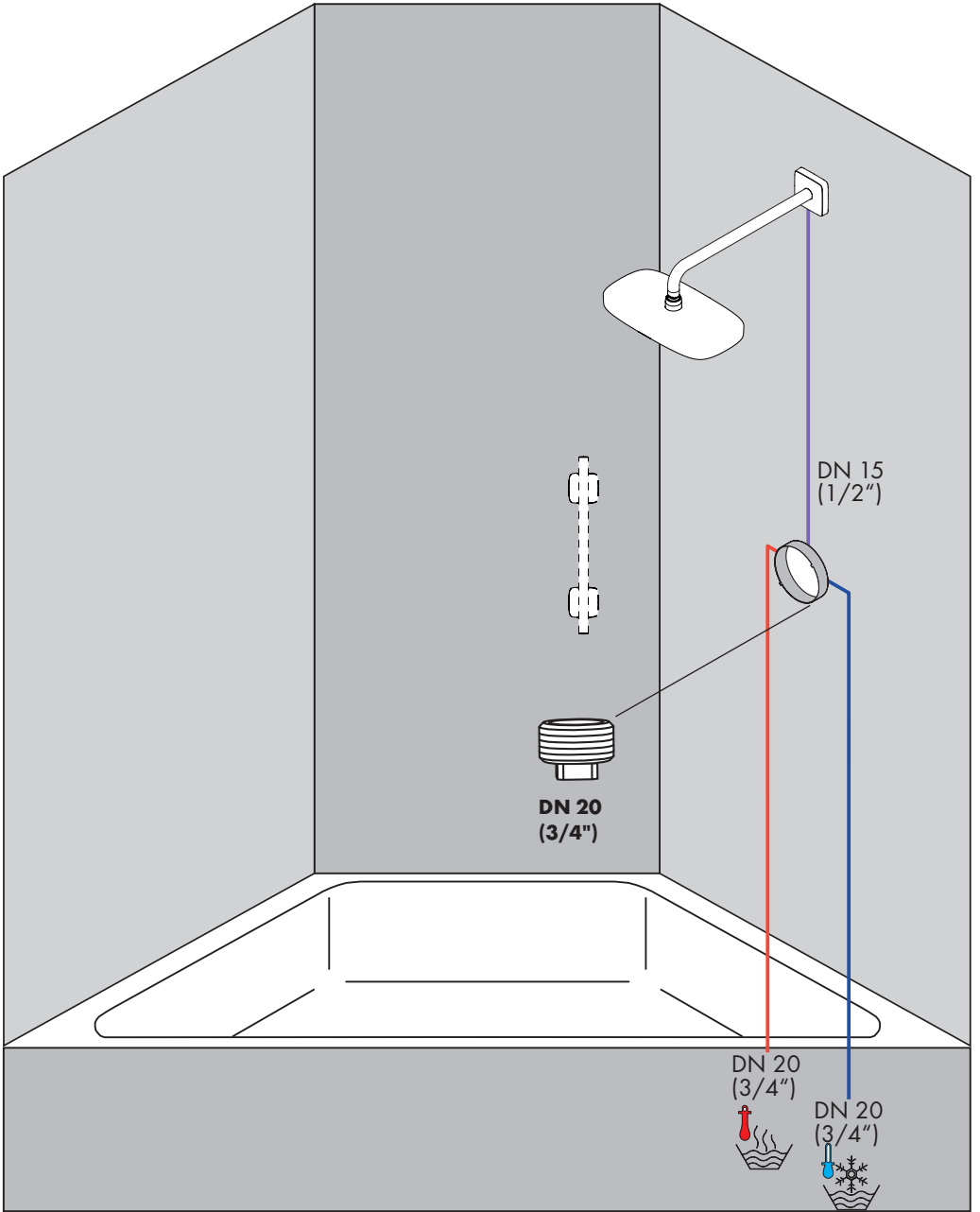

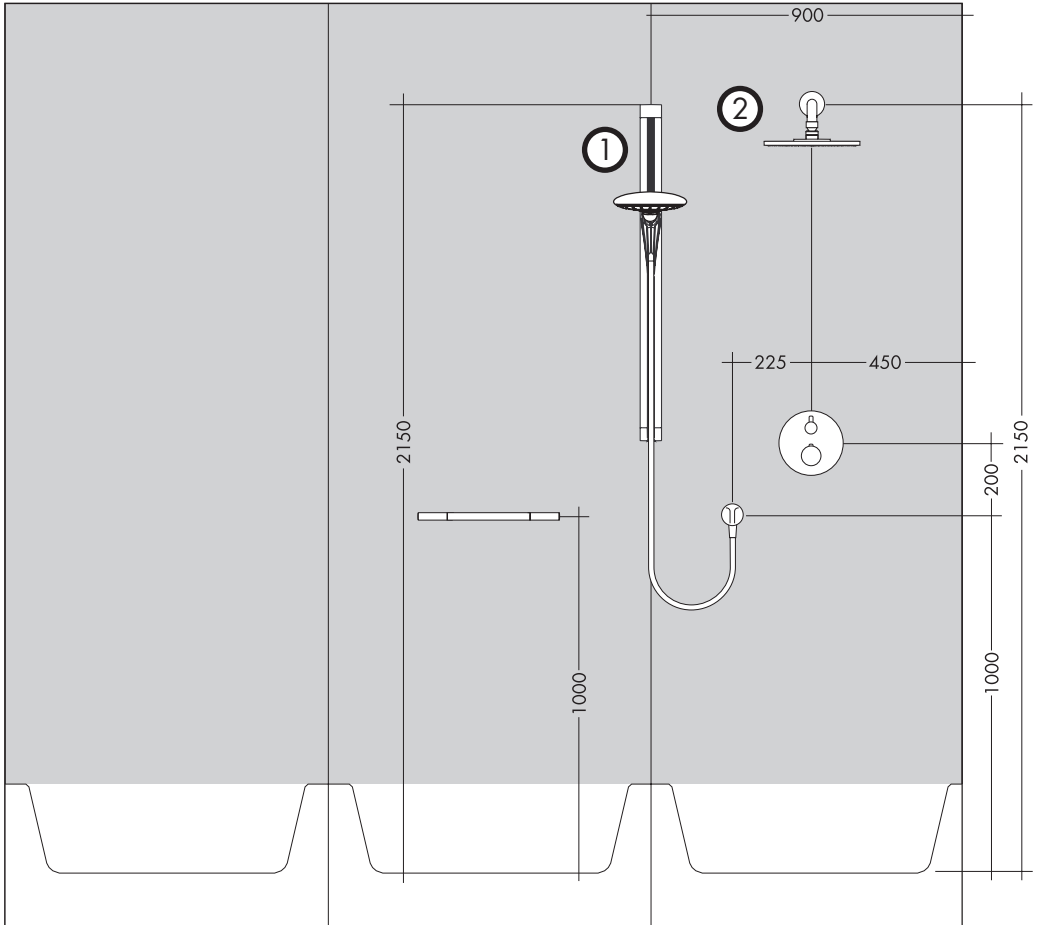
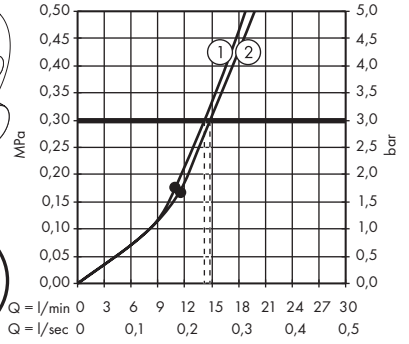
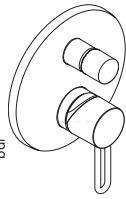
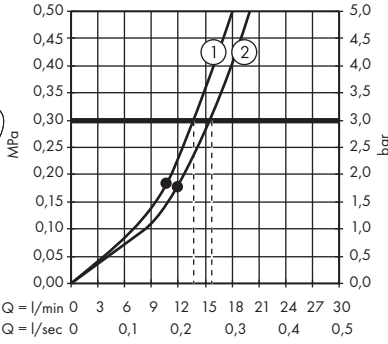
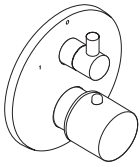



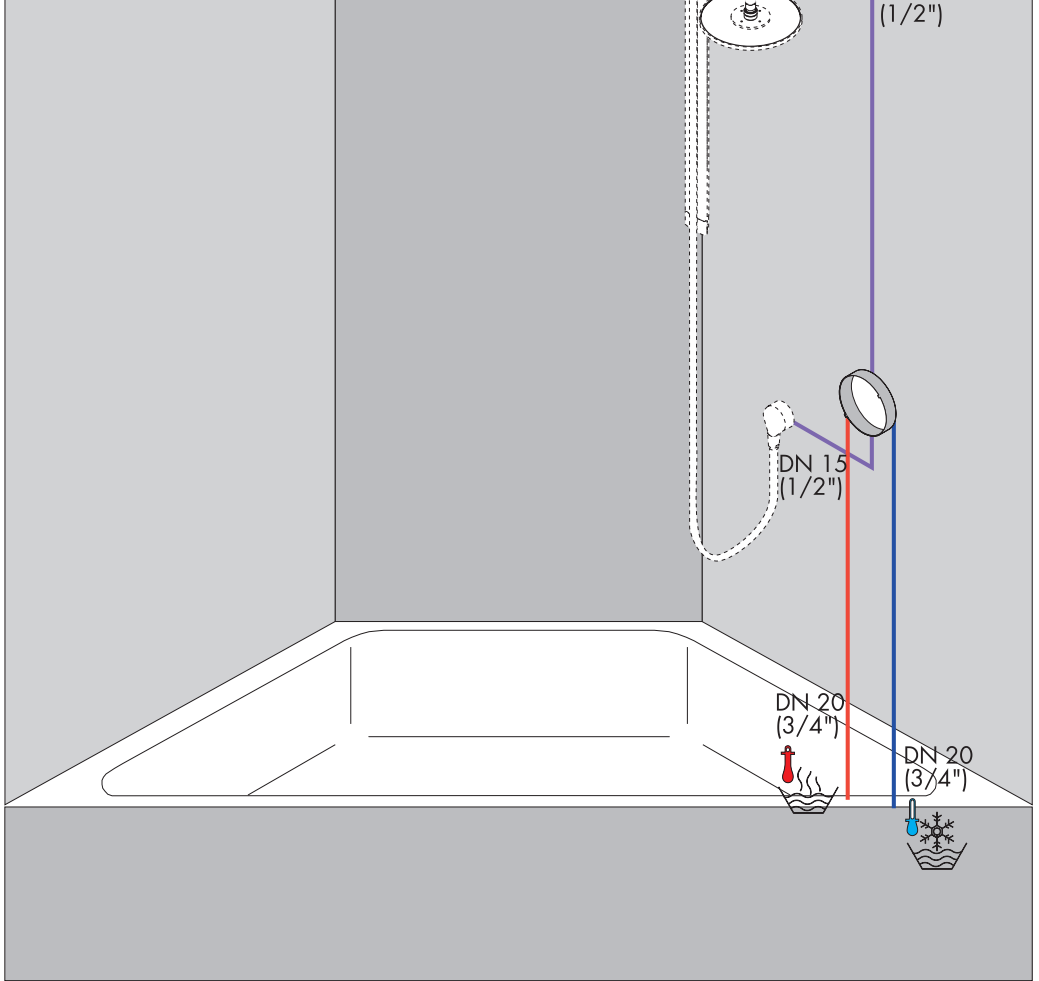
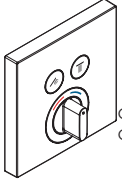
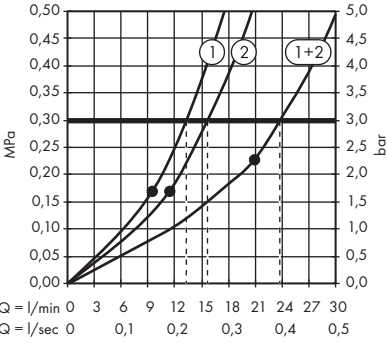
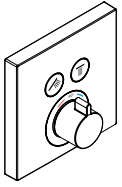

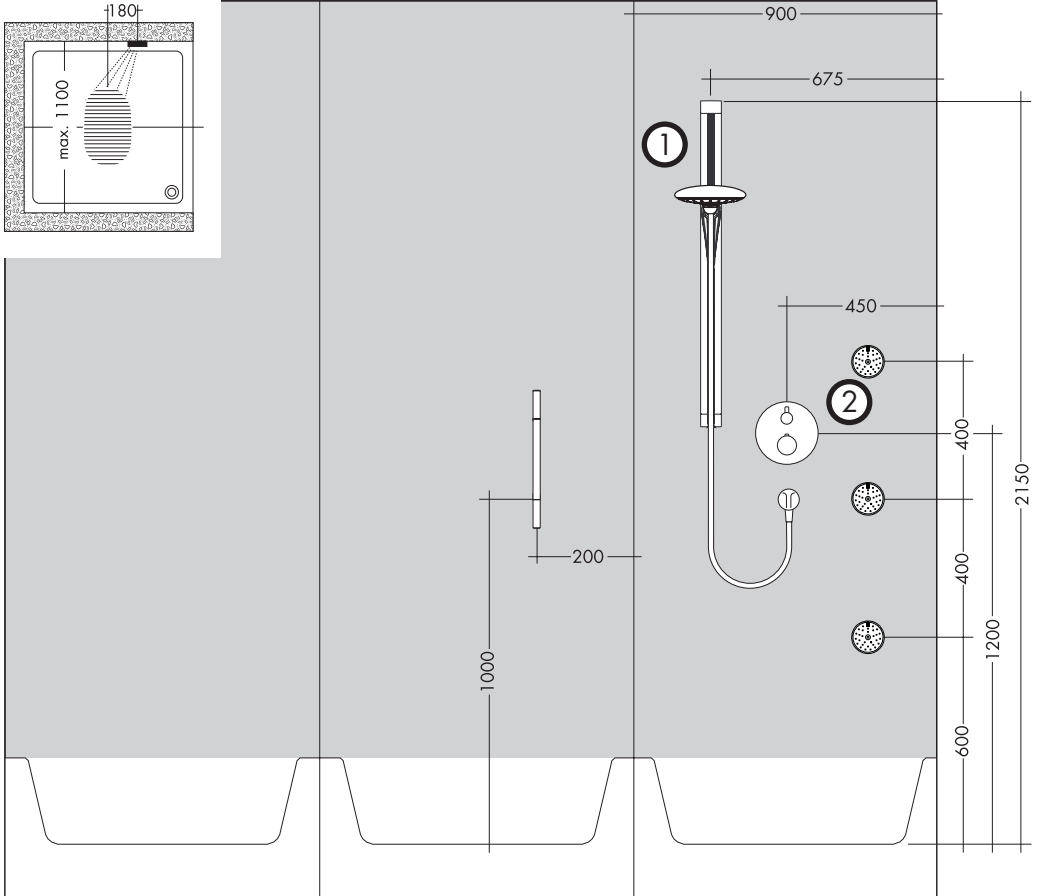
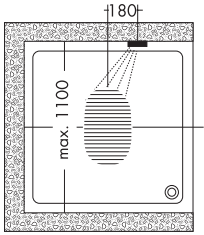
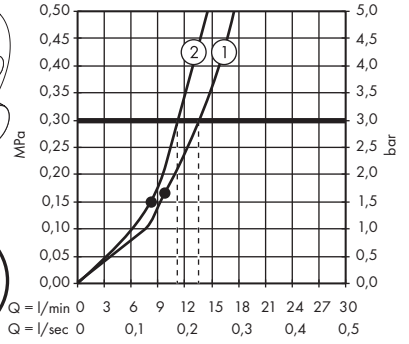
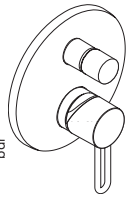
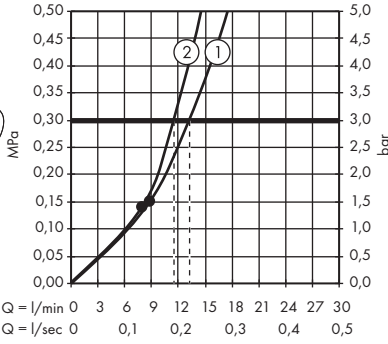
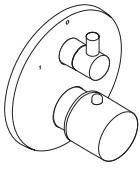

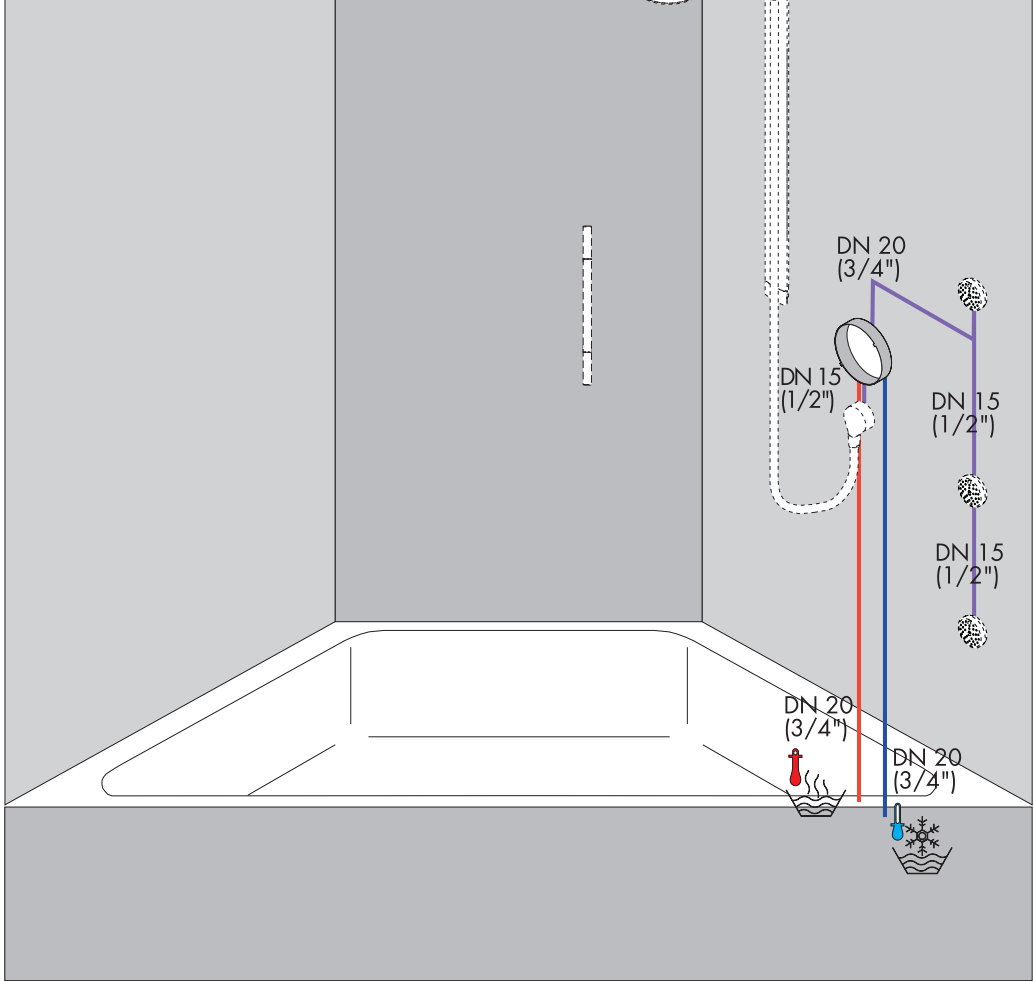
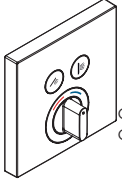
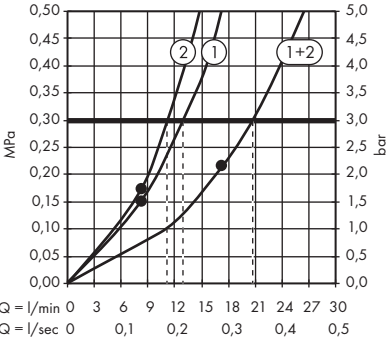
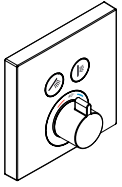

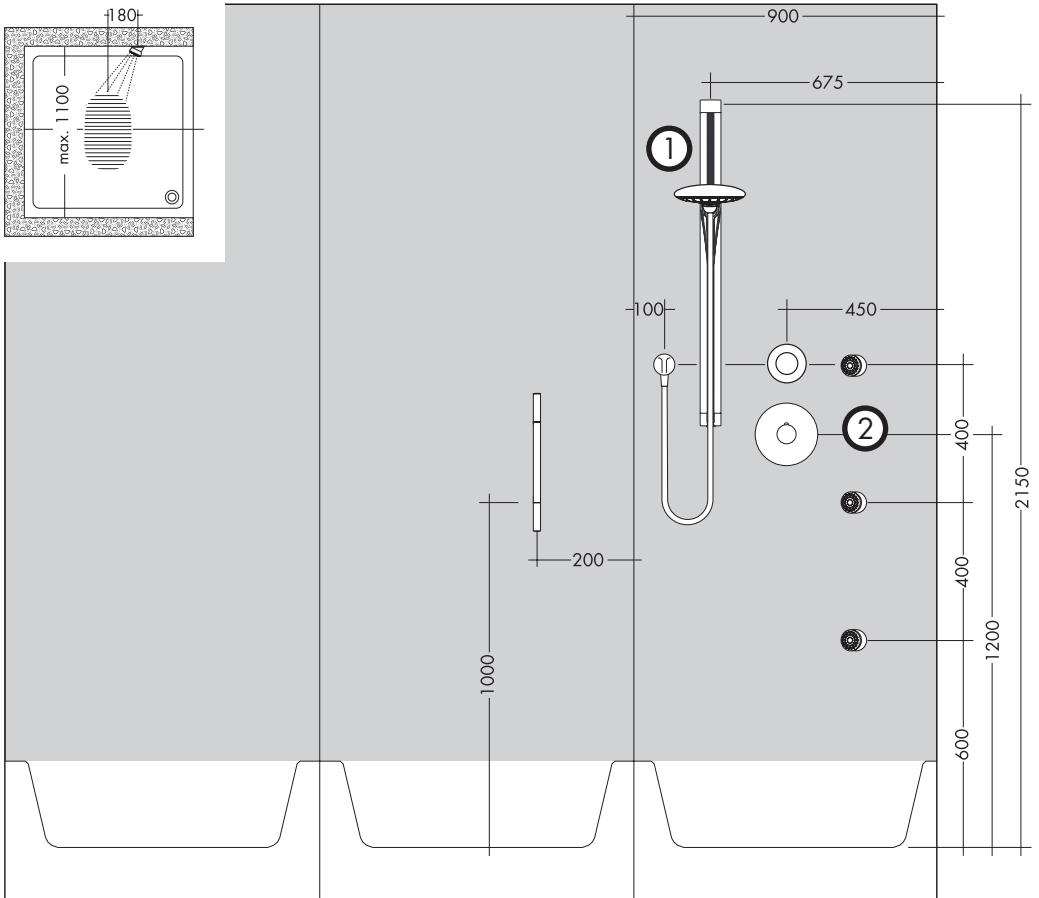
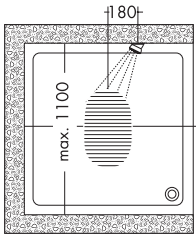
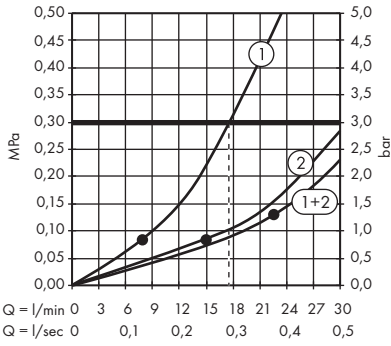
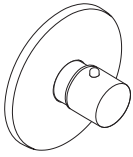



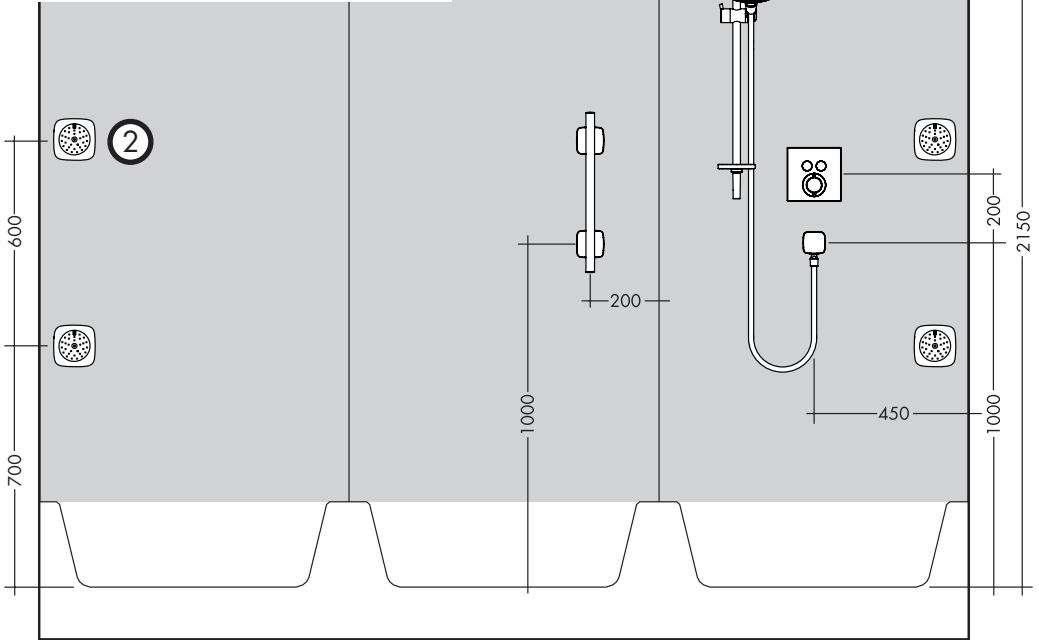
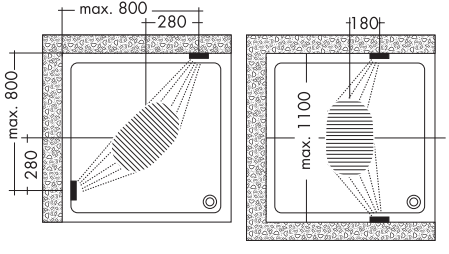
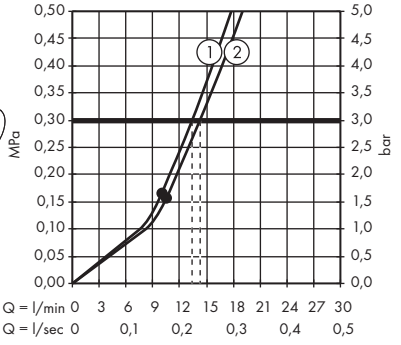
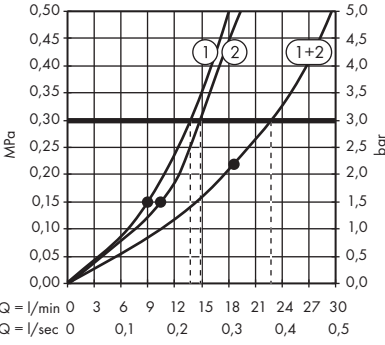
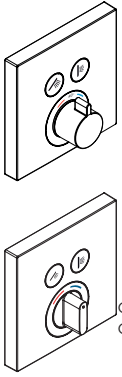

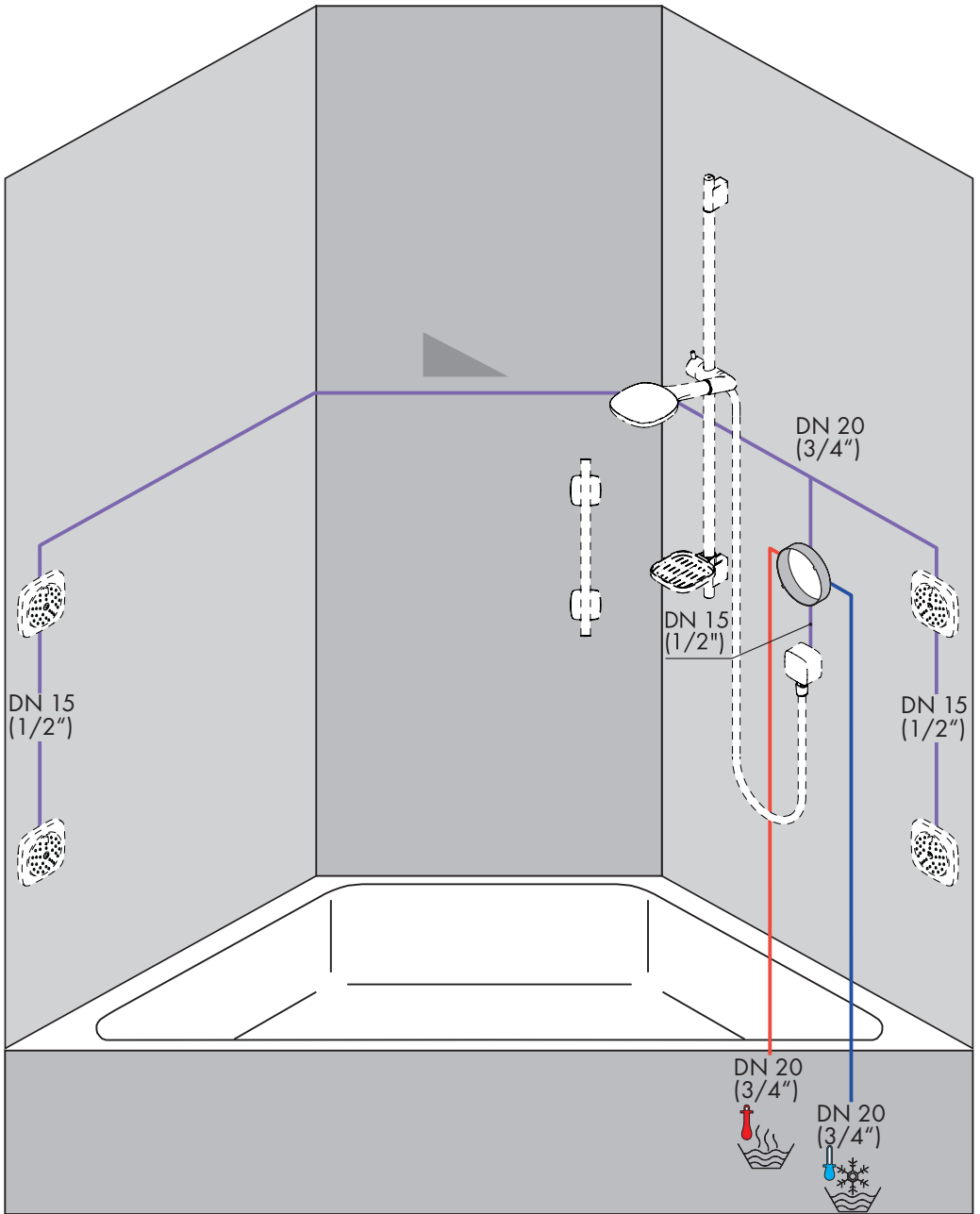

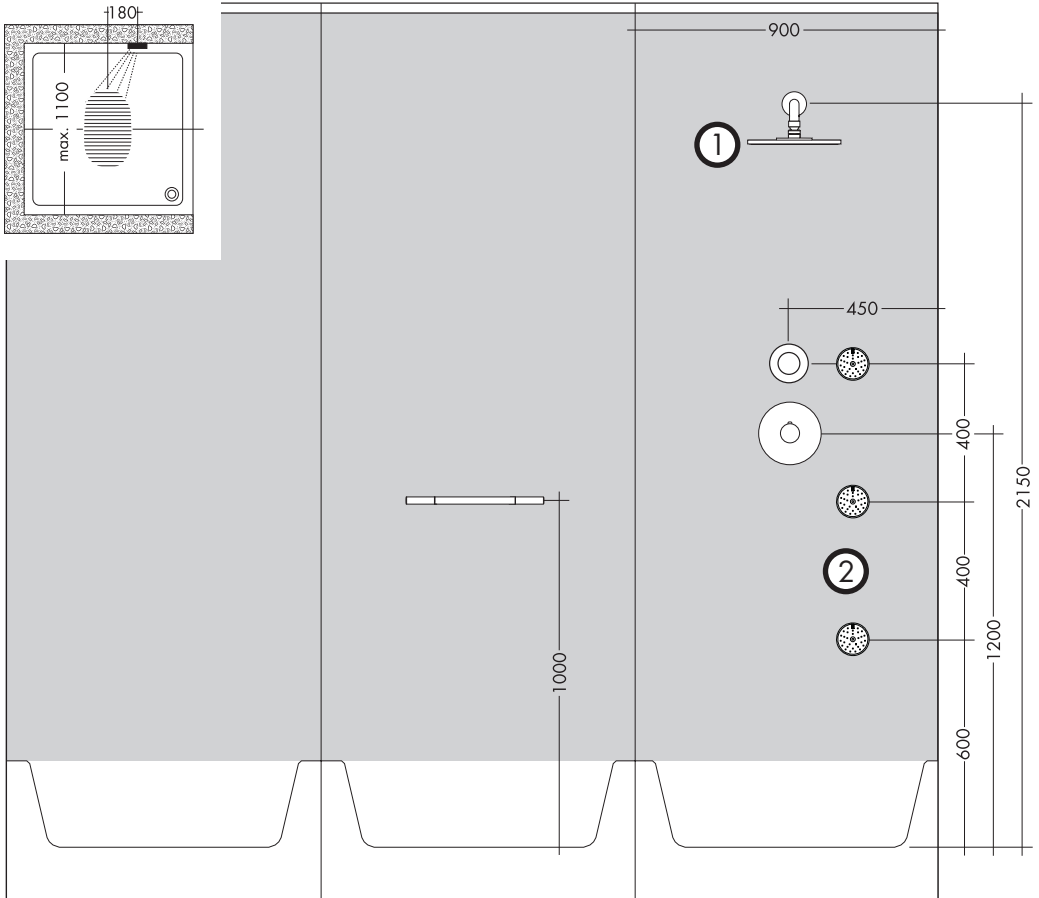
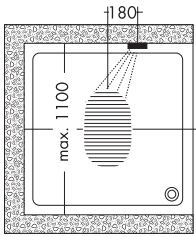
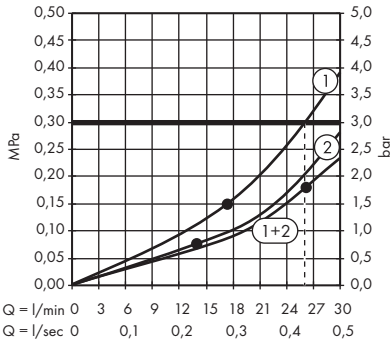
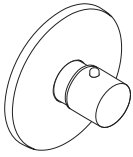



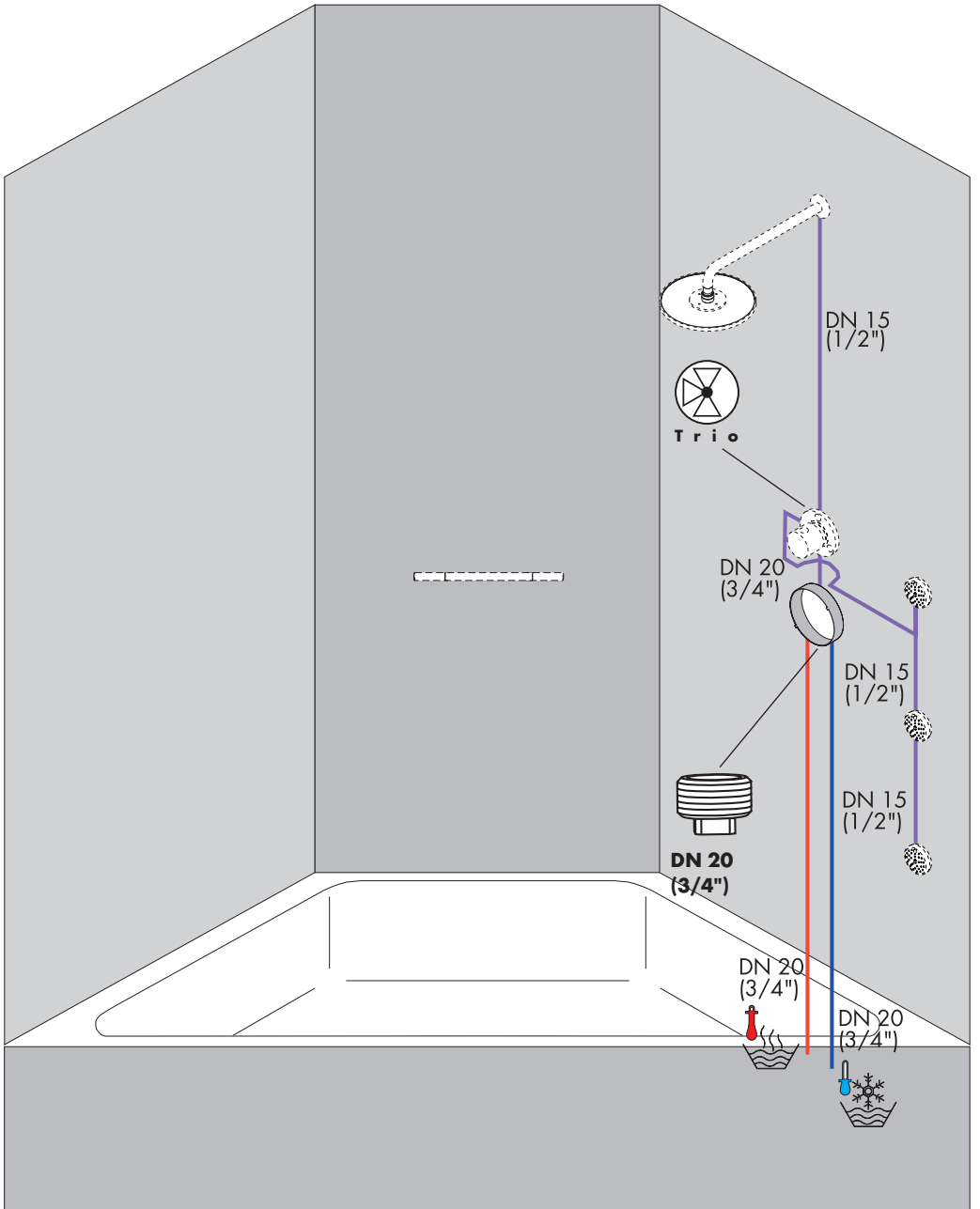

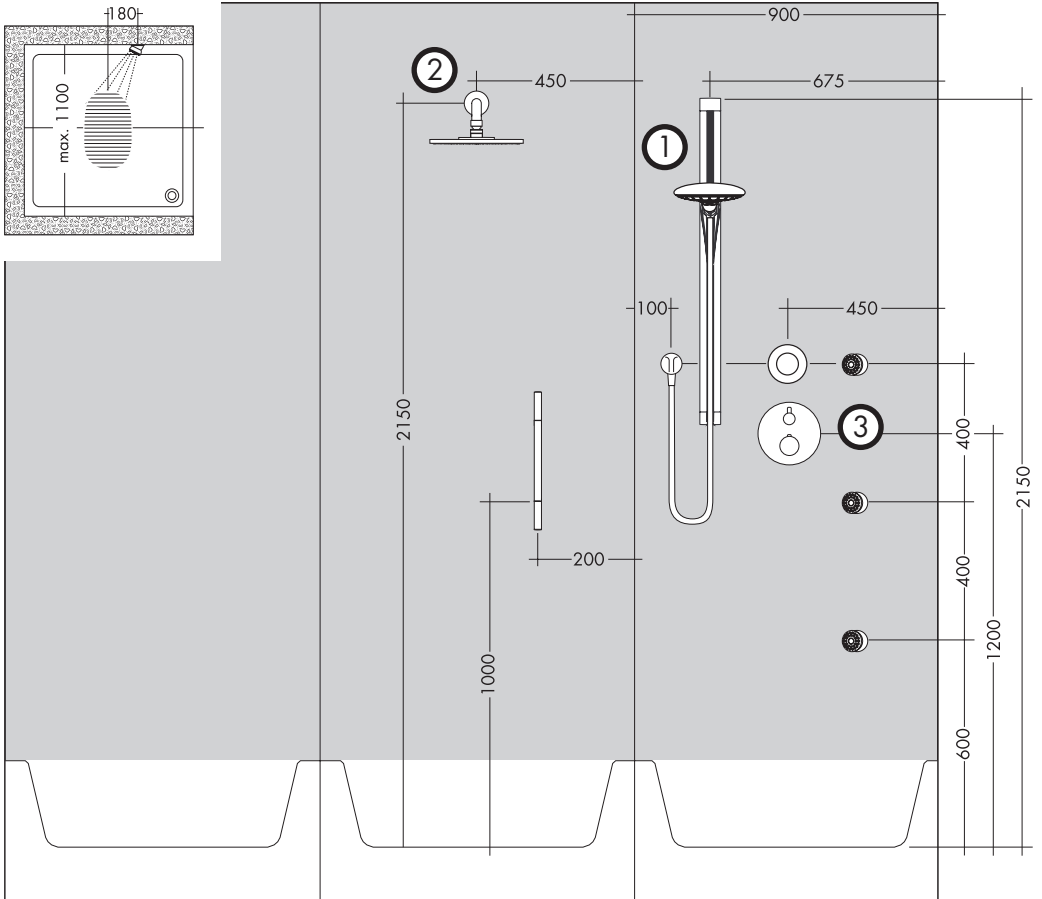
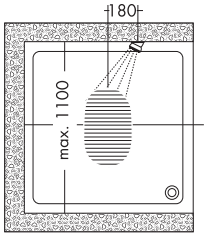
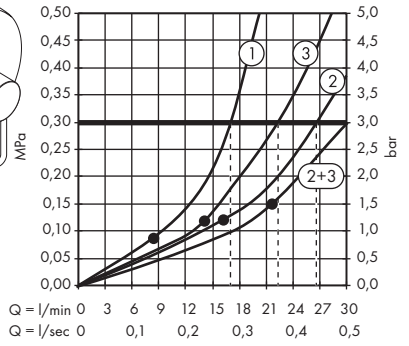
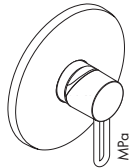
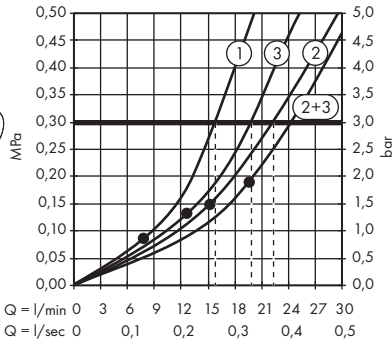
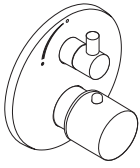





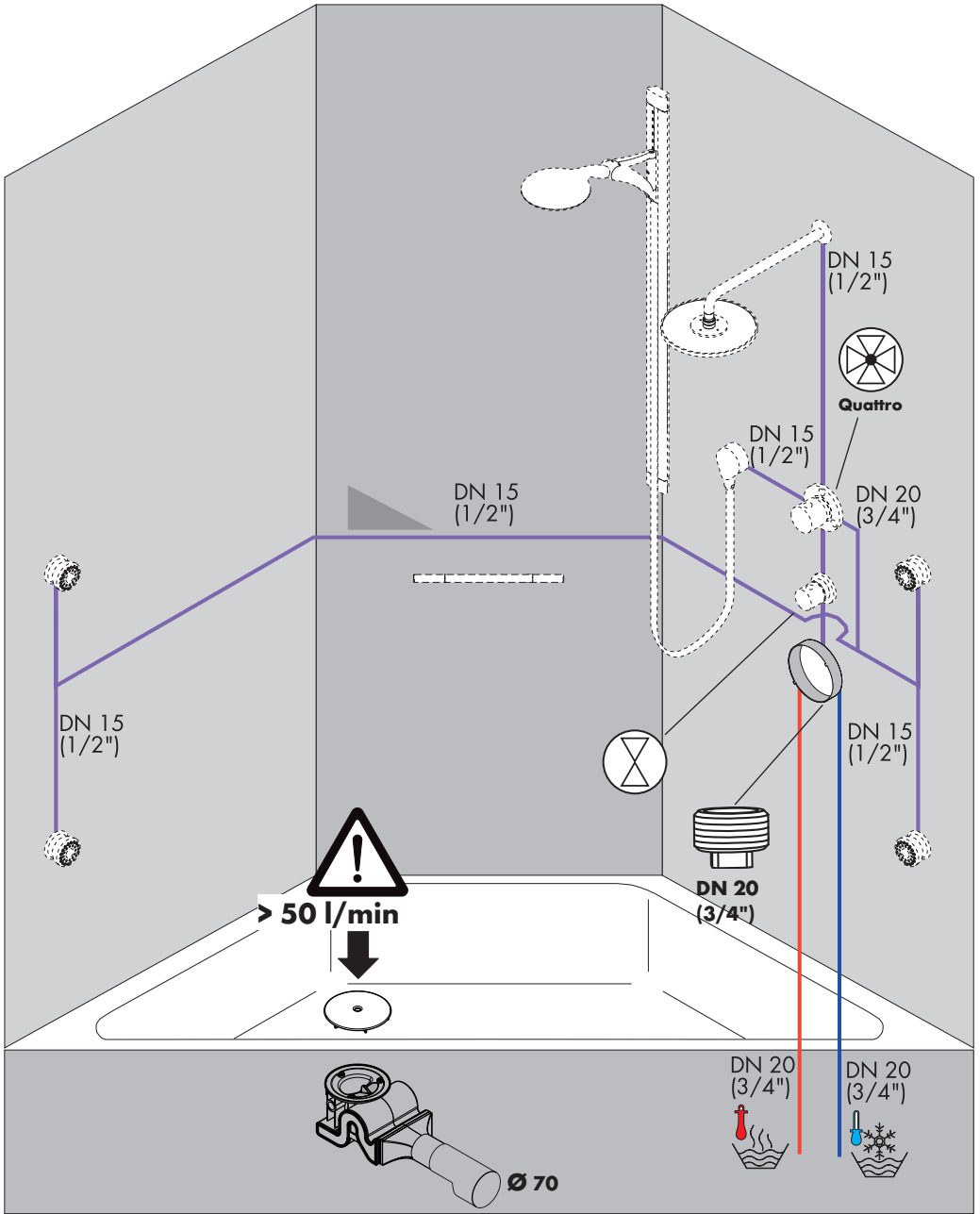



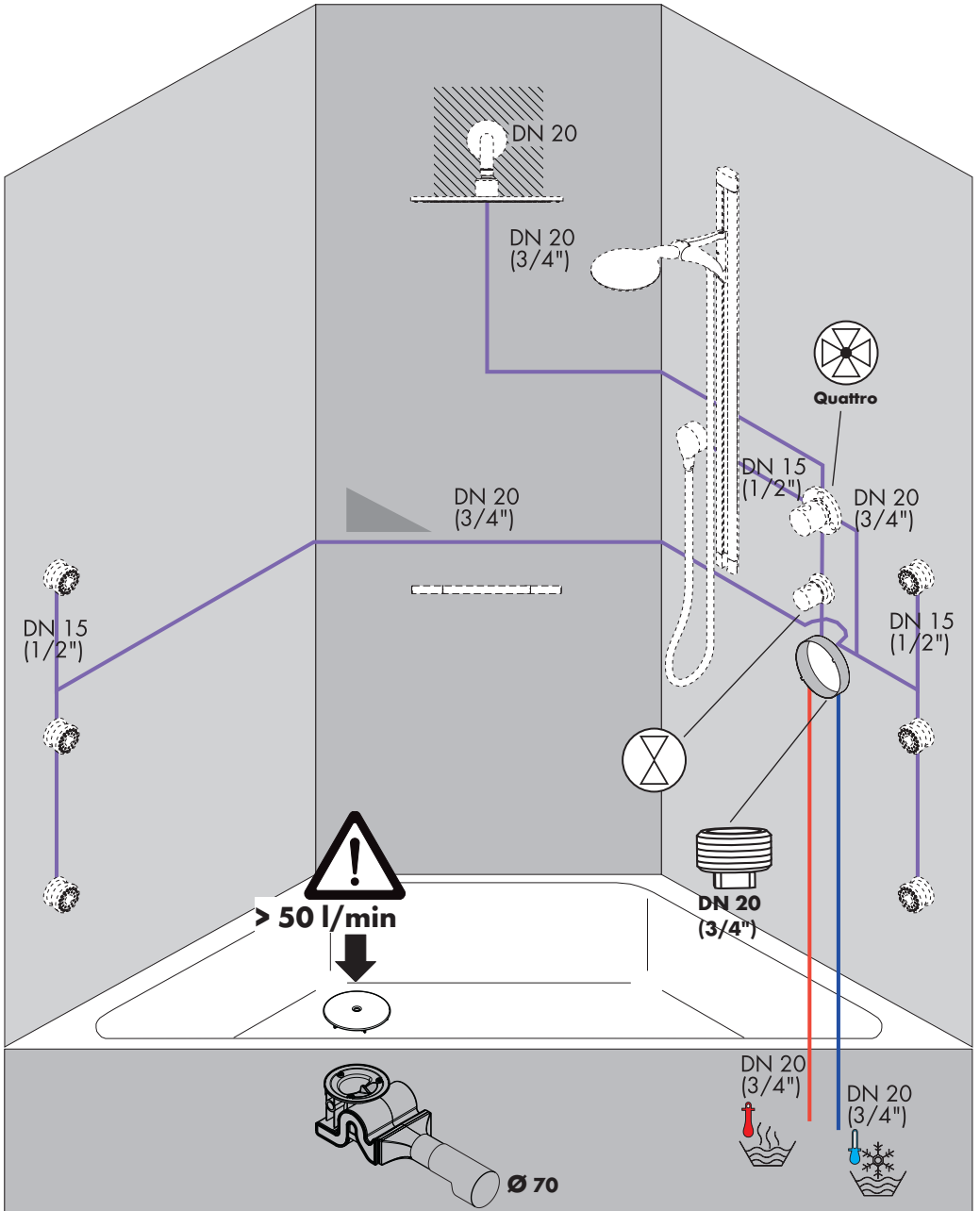





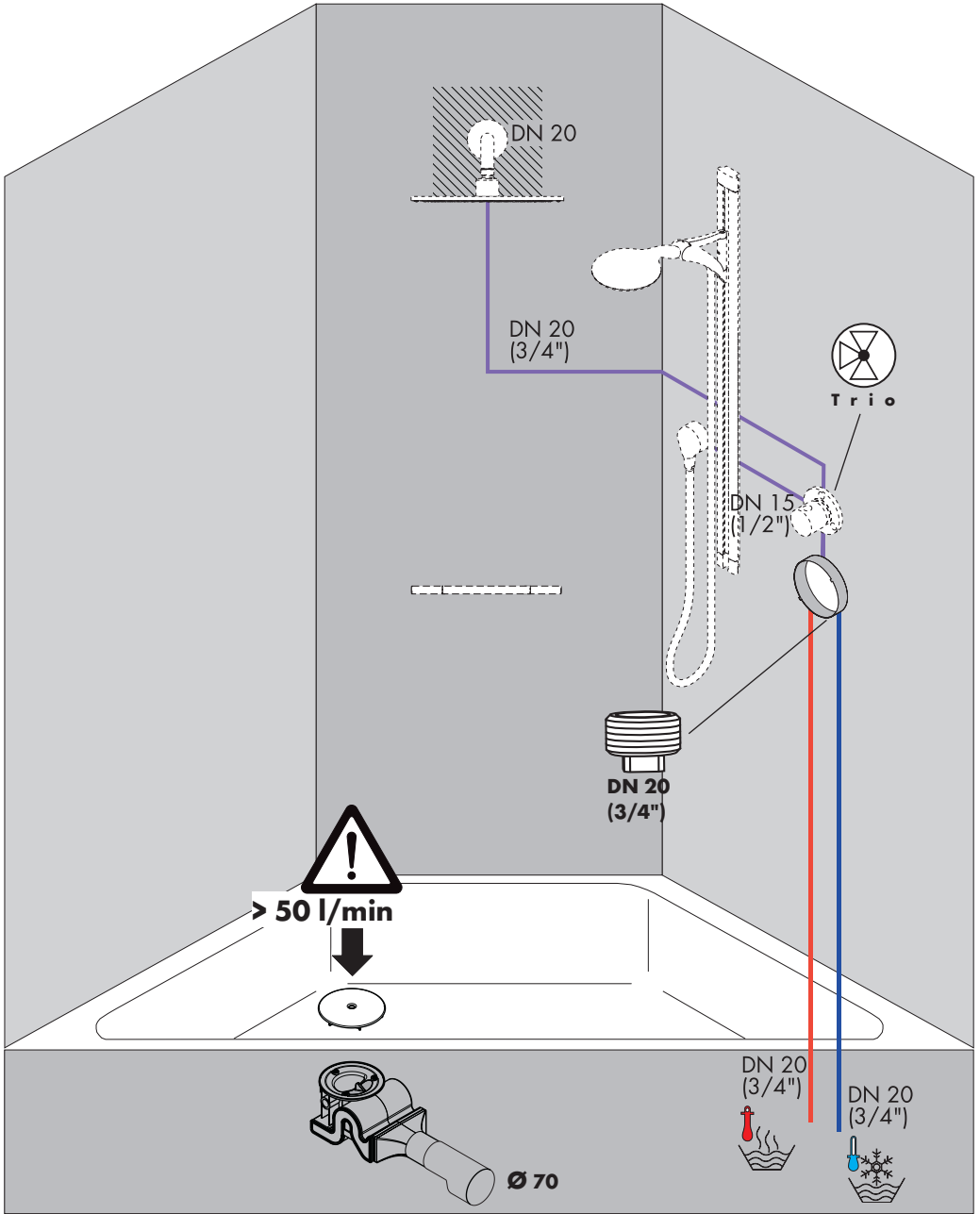

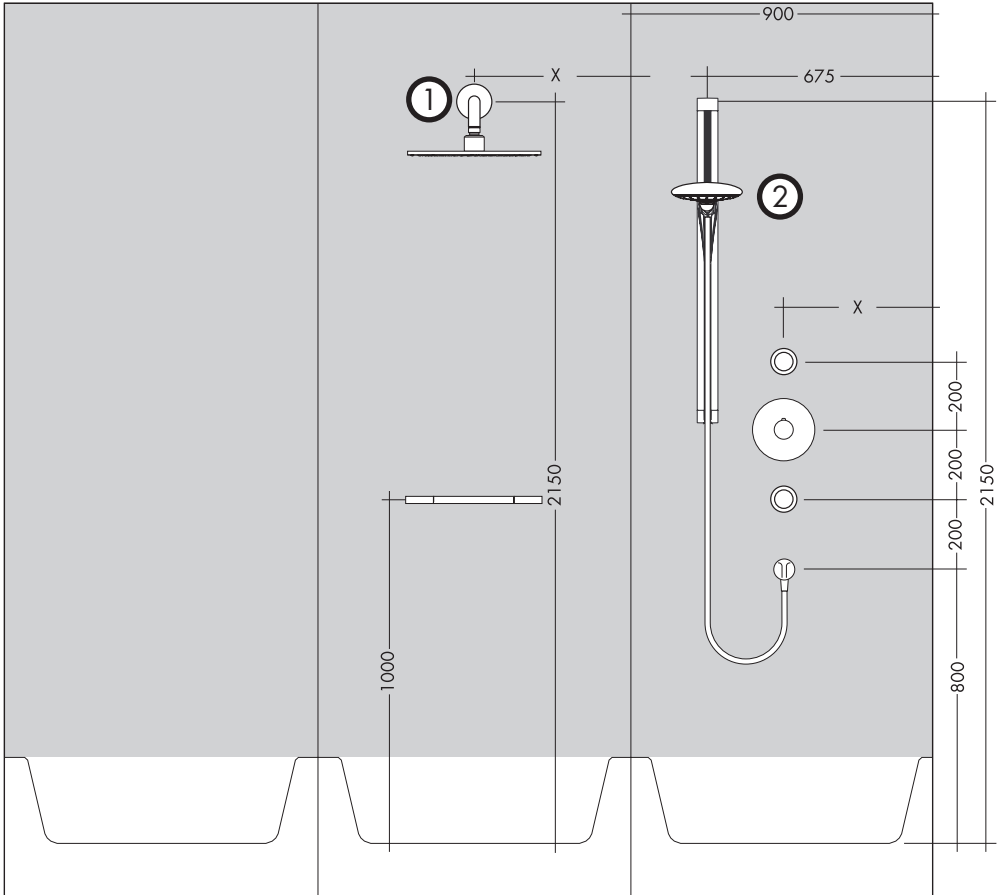
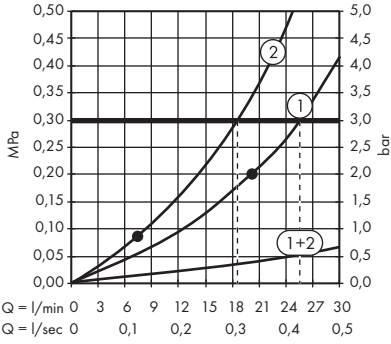
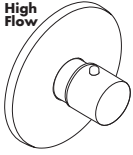

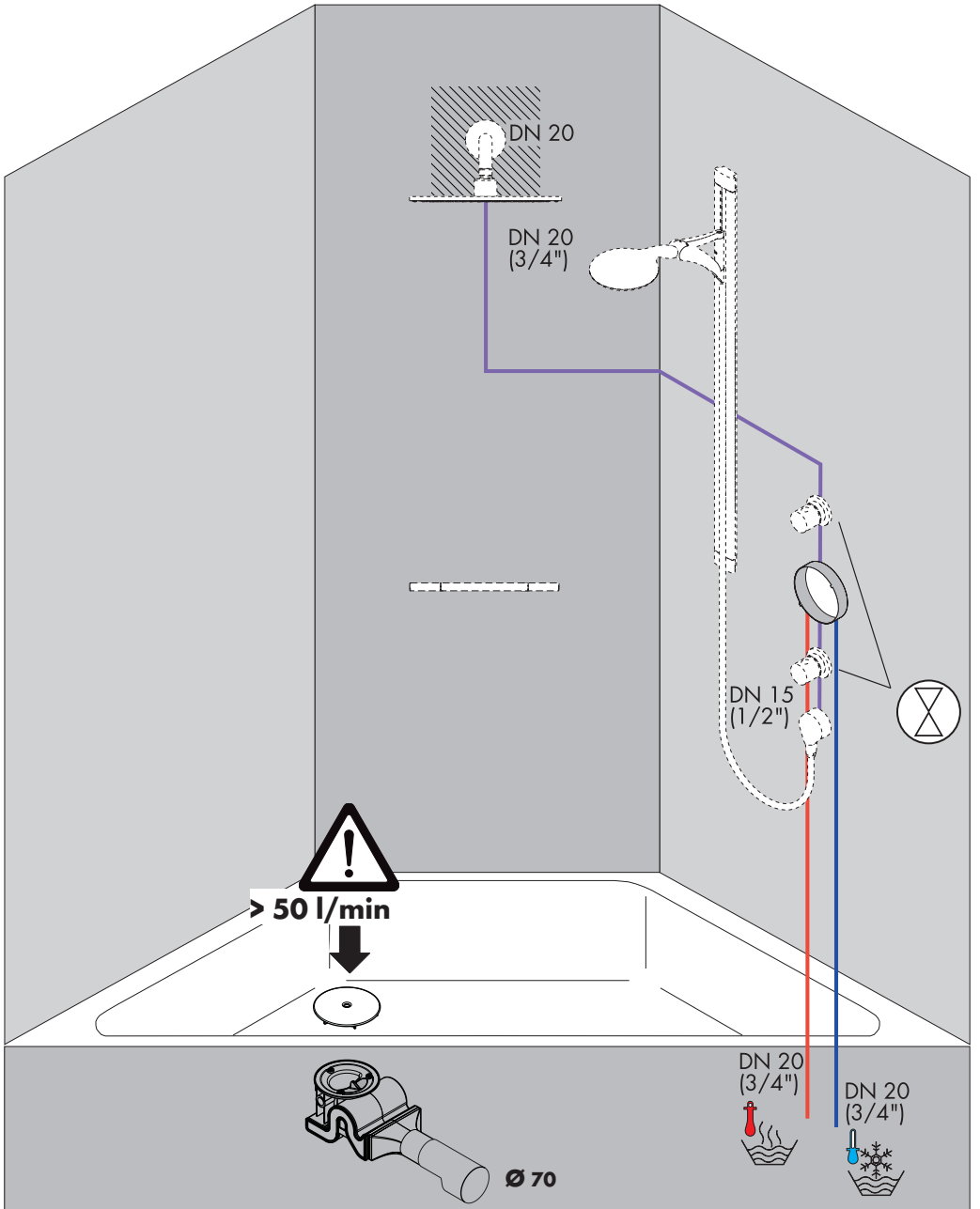

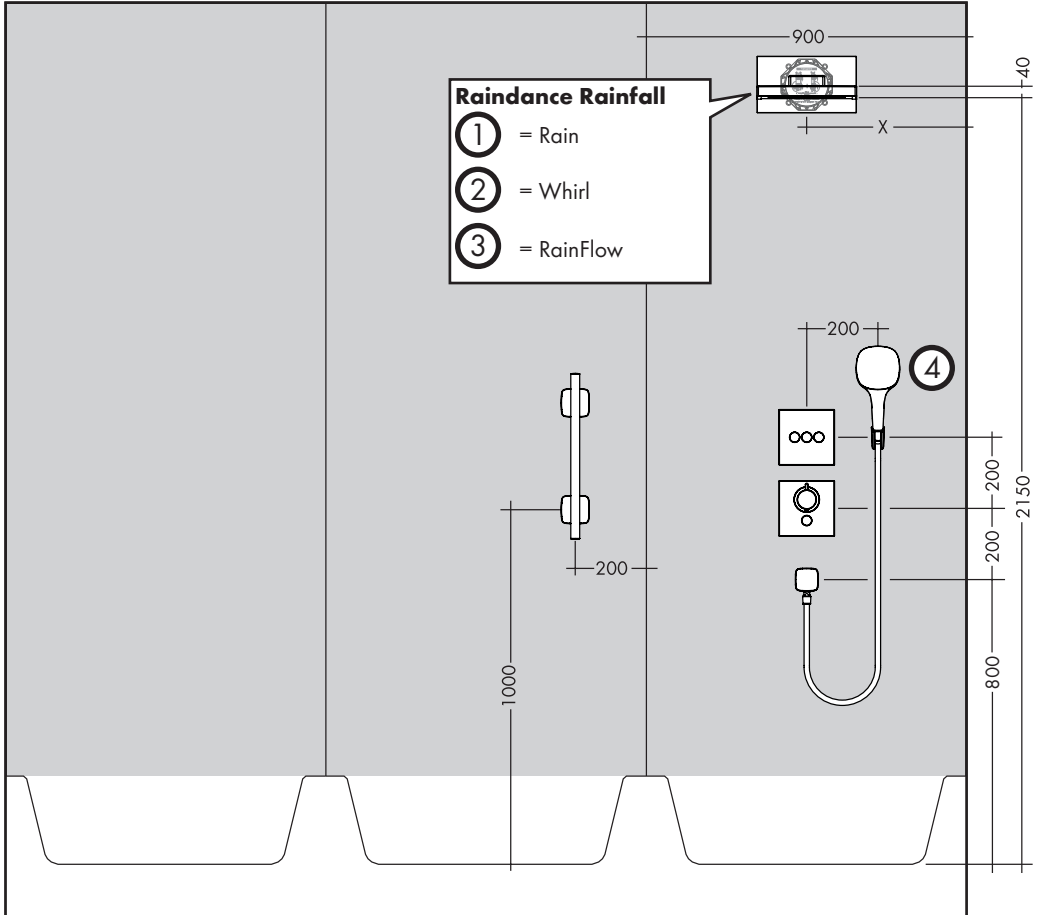
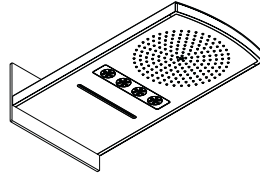
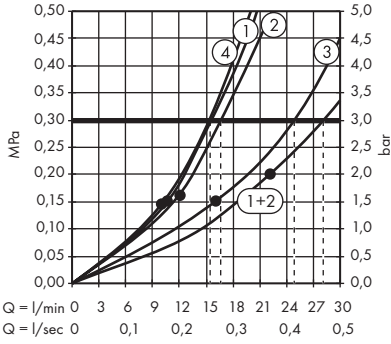
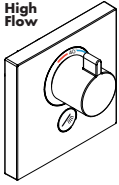
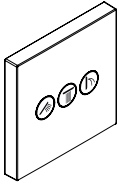

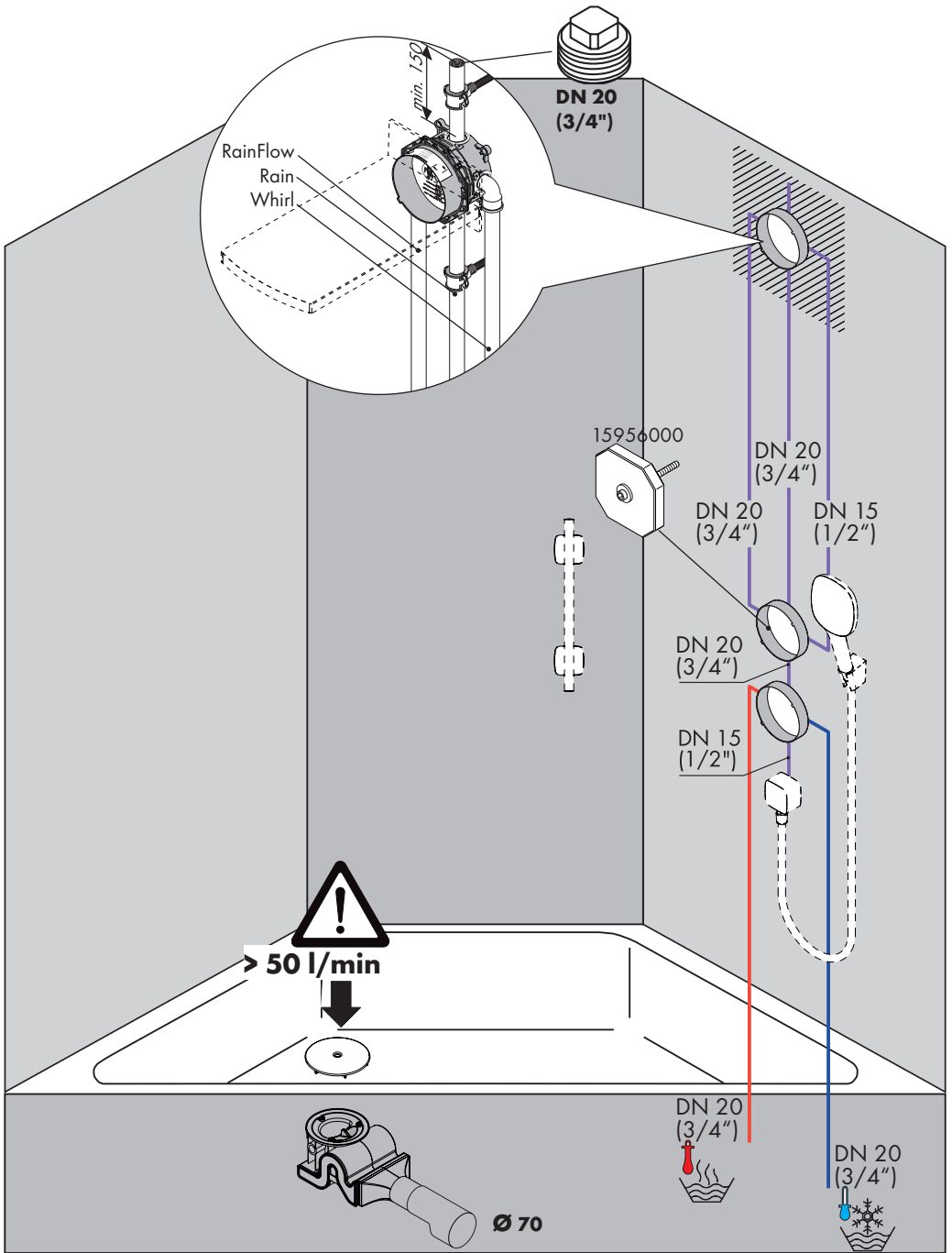

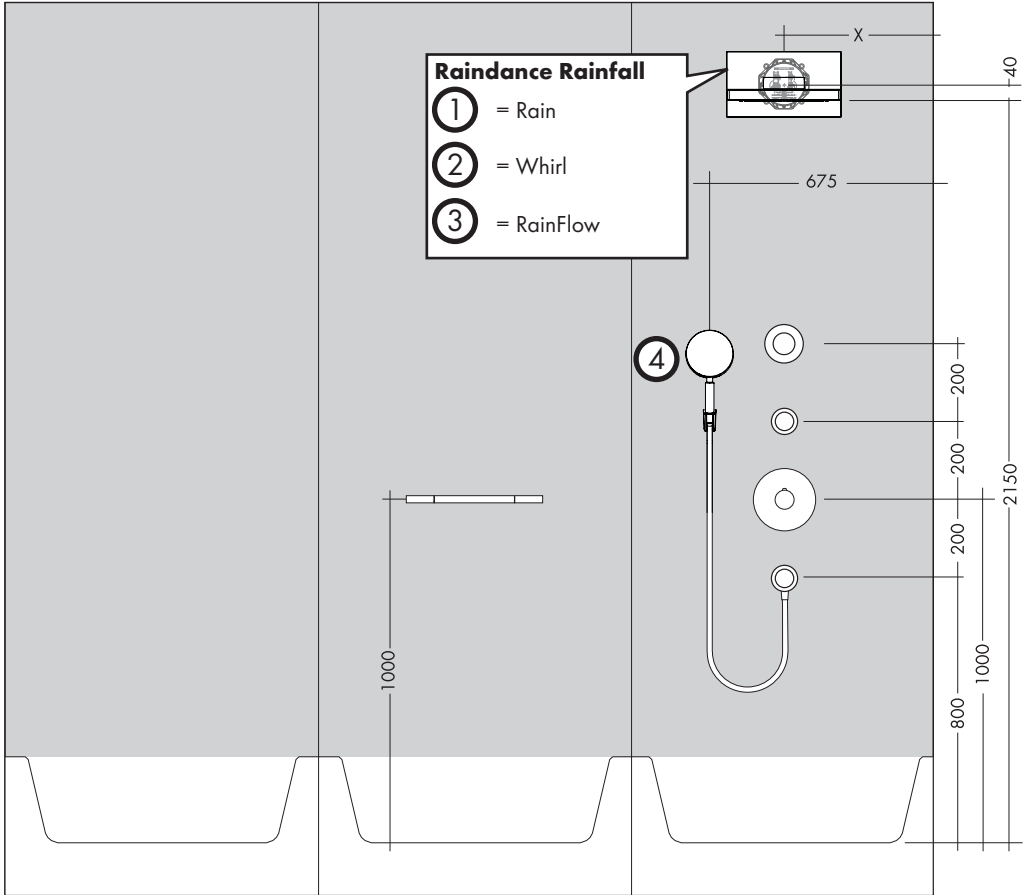
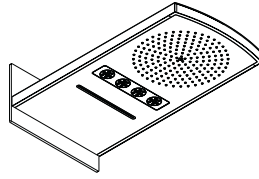
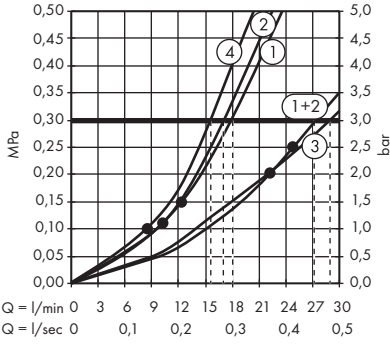
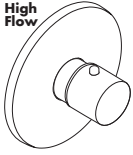

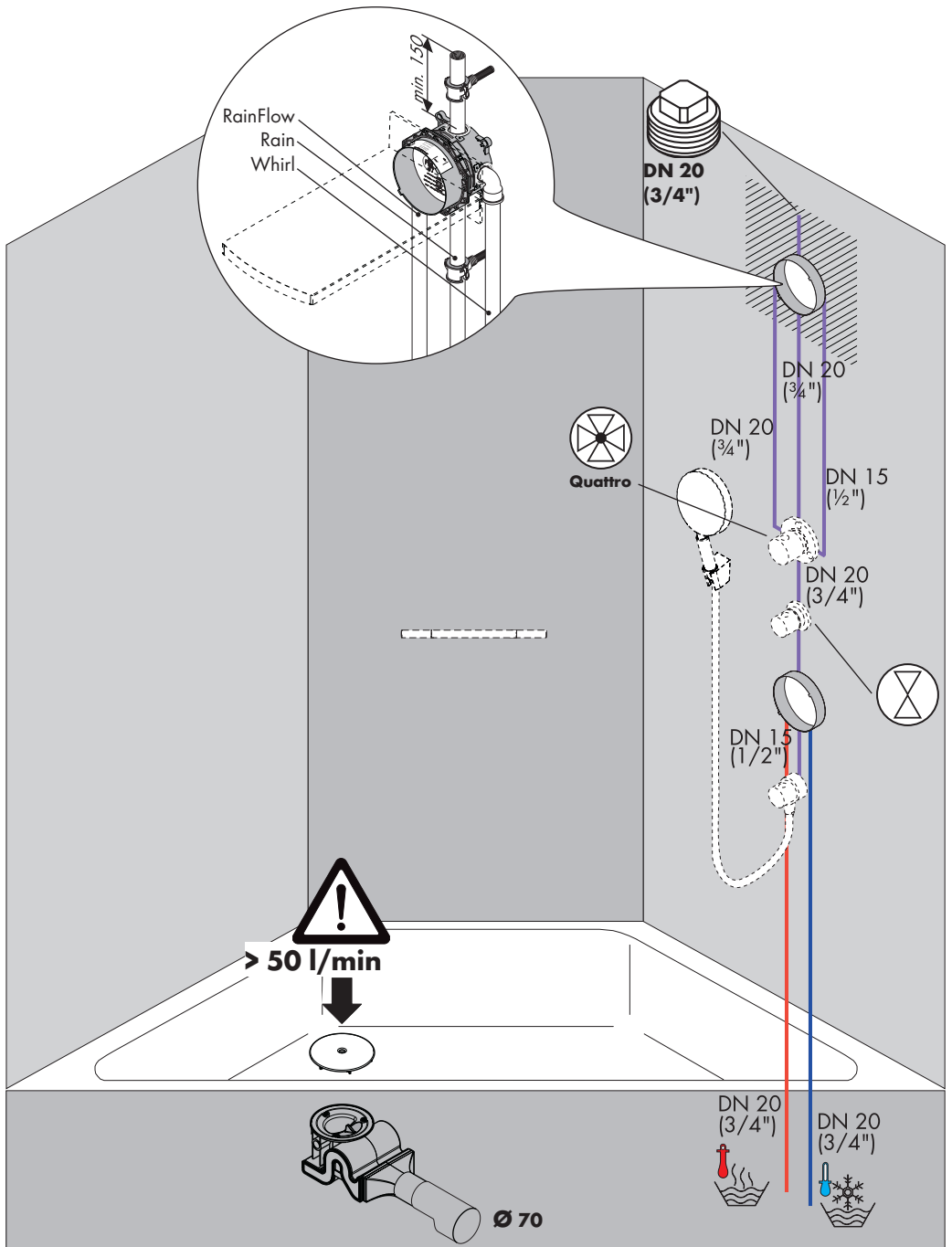

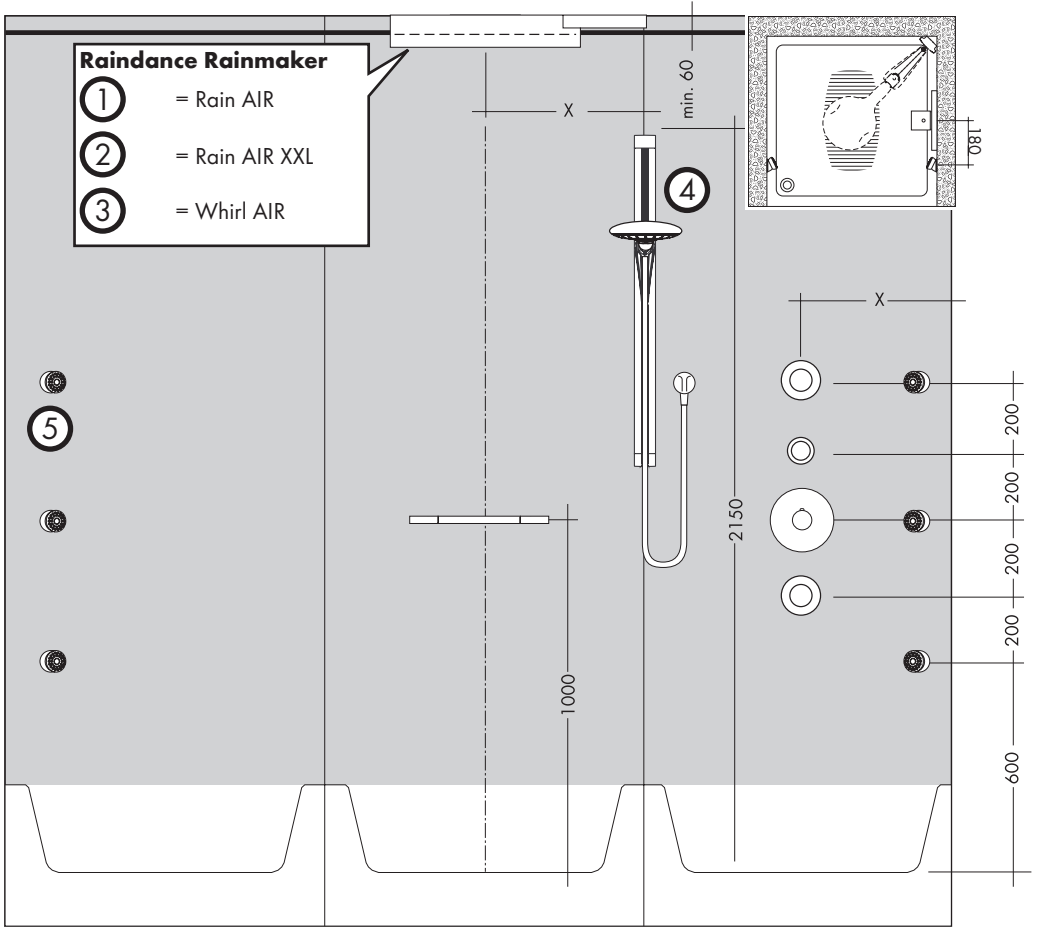
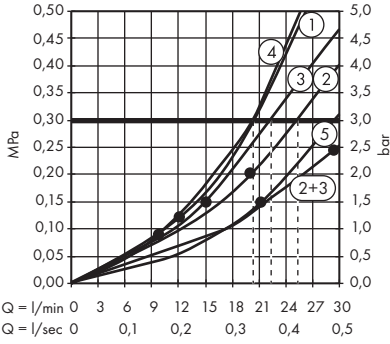
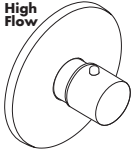



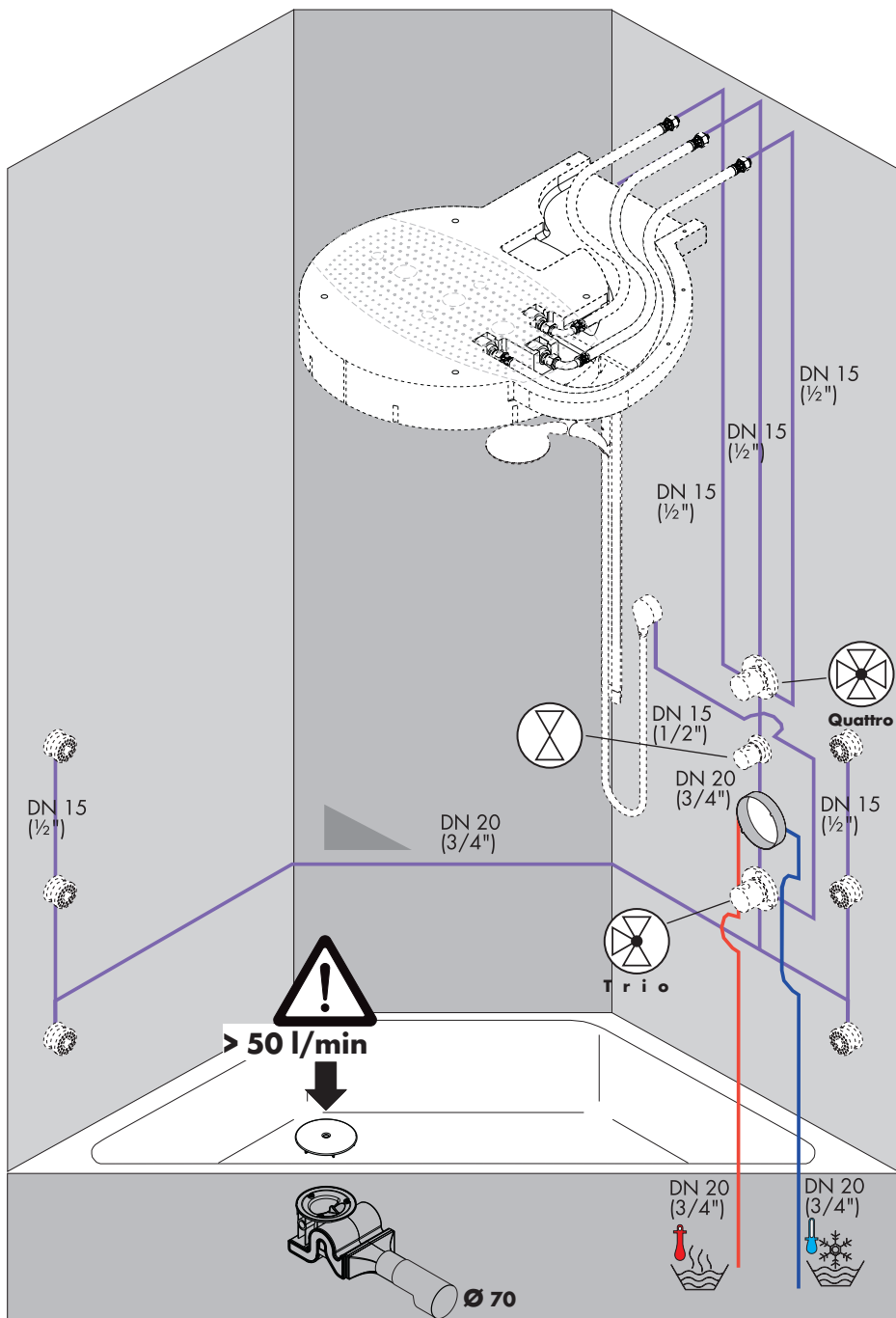

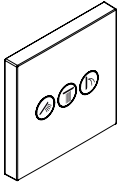

High Flow

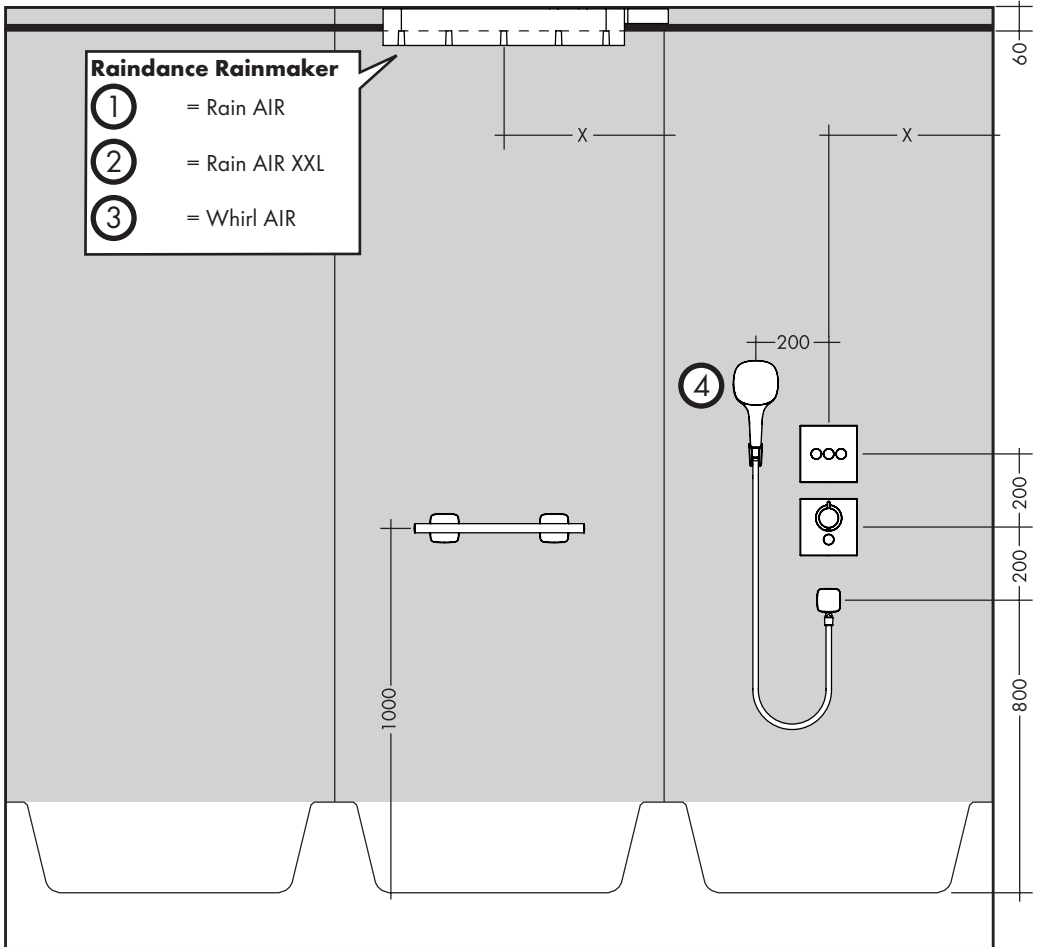
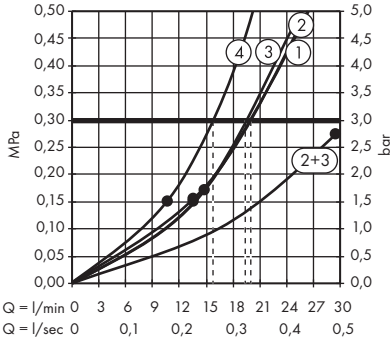
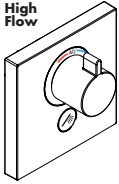

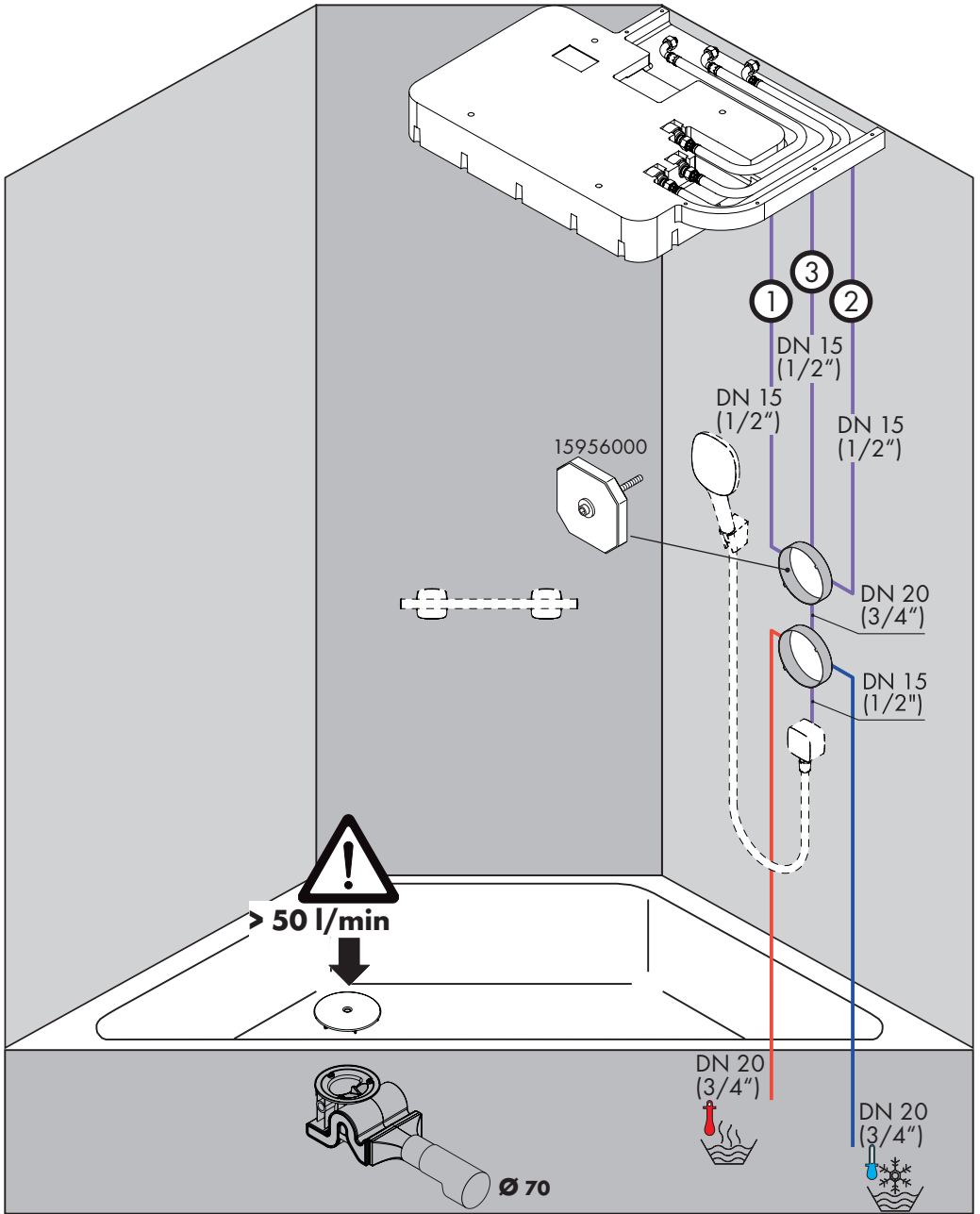

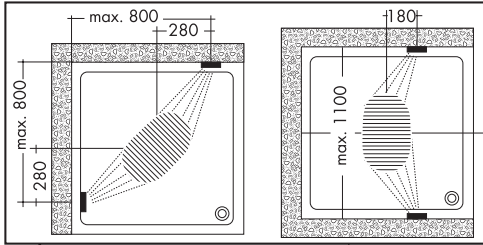
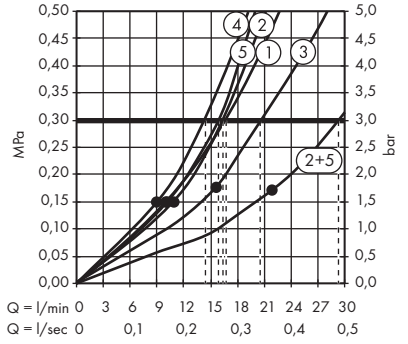
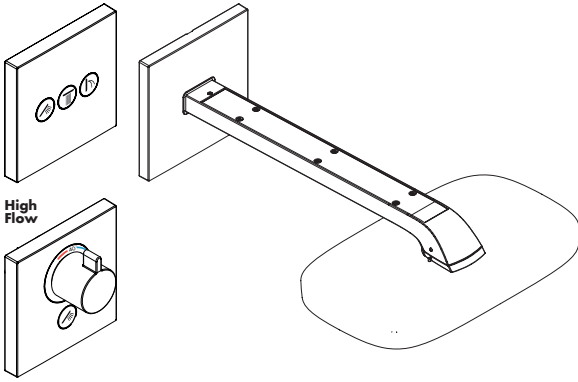

### Raindance Select 300

- ① = Rain
- ② = RainAir
- ③ = RainStream

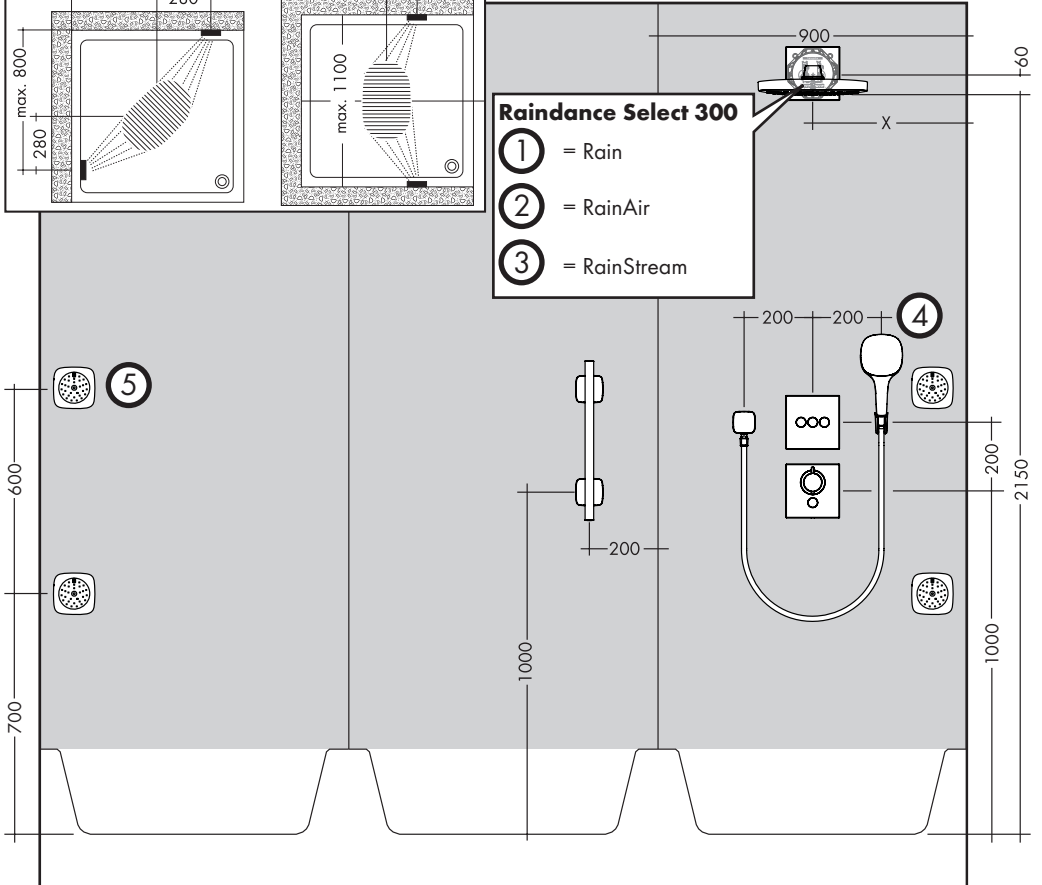

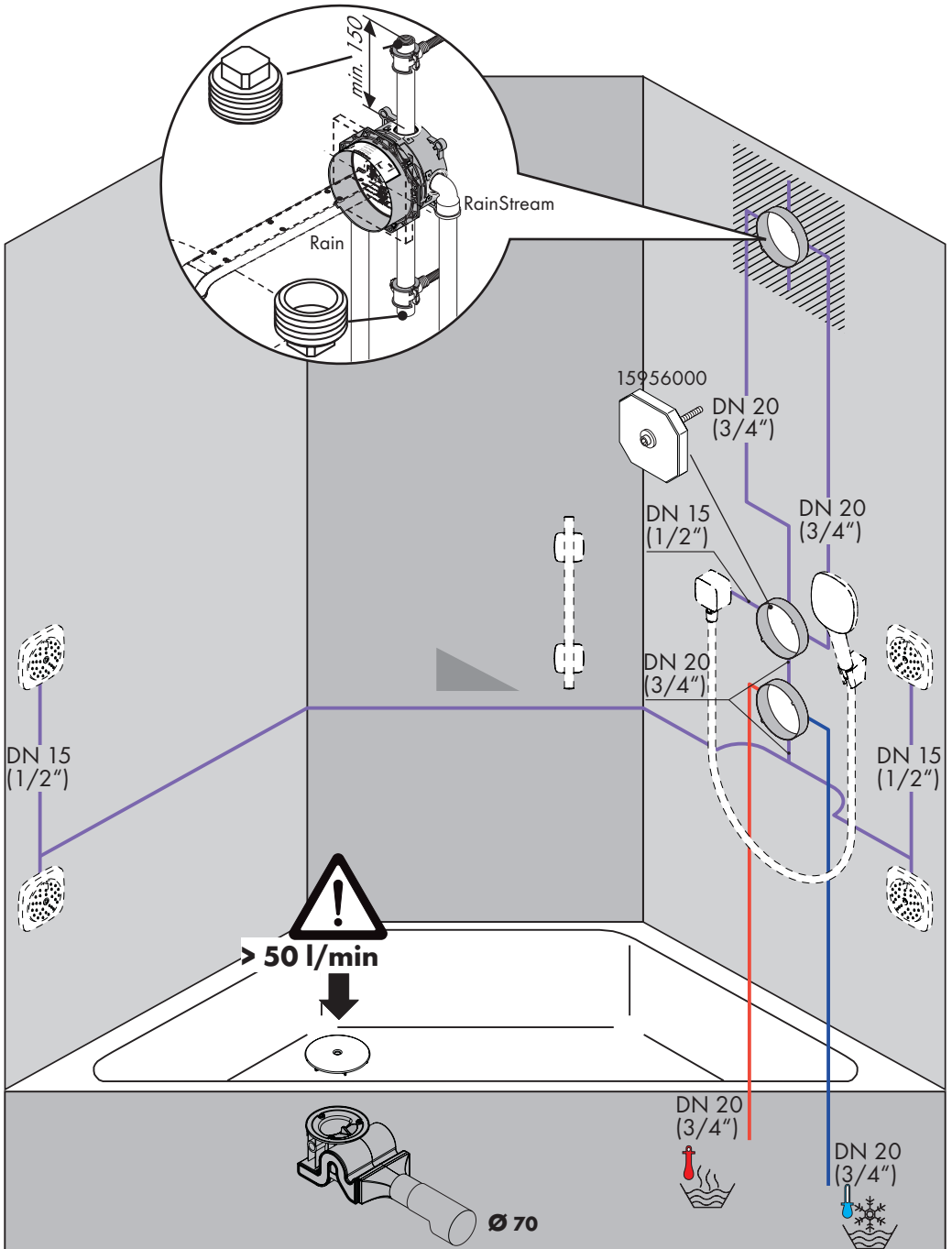

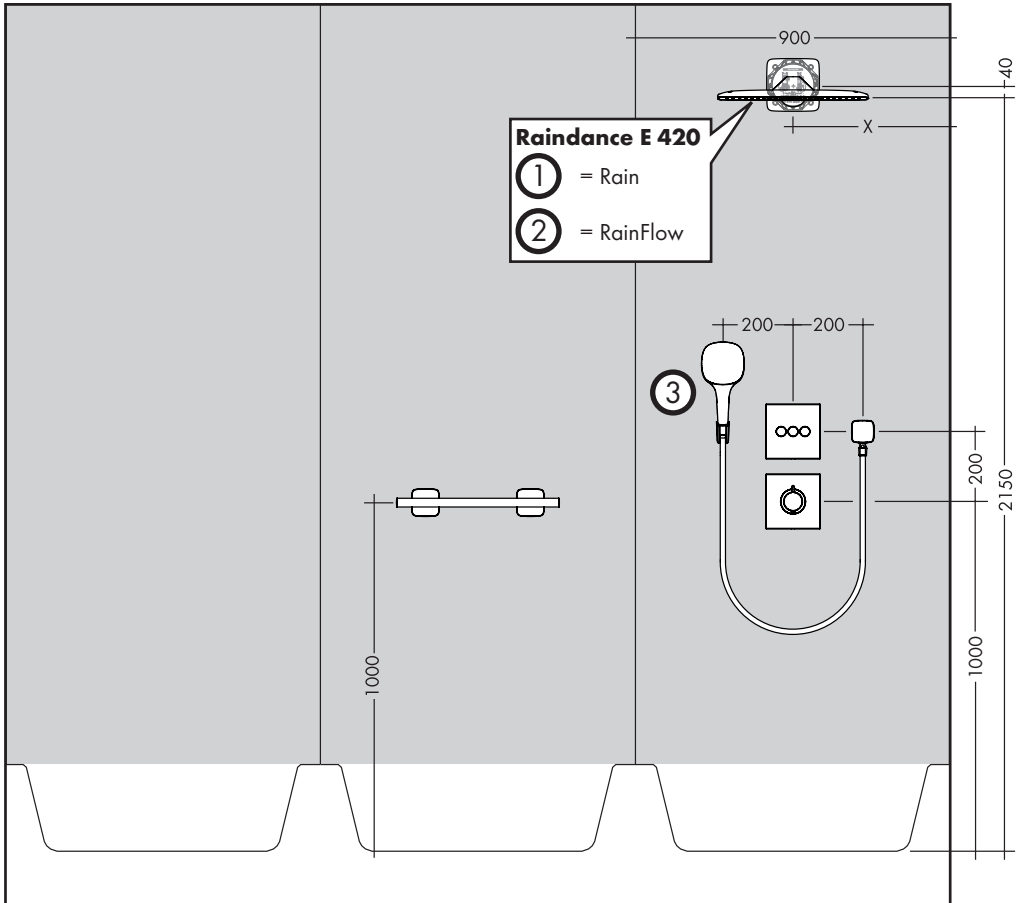
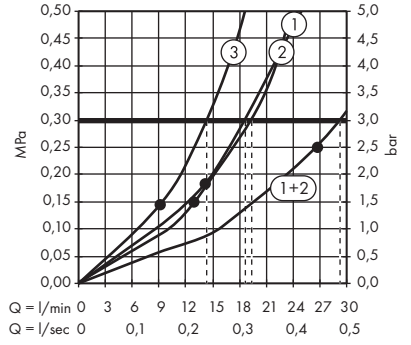
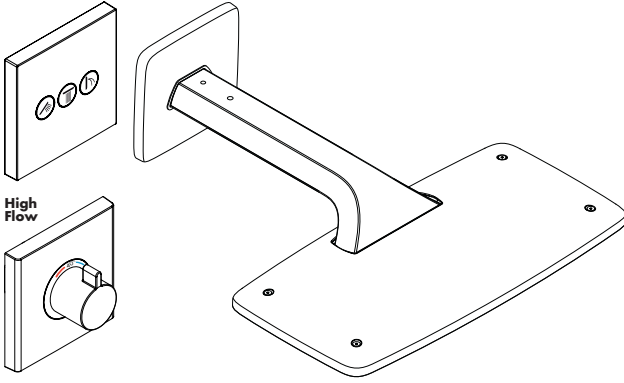

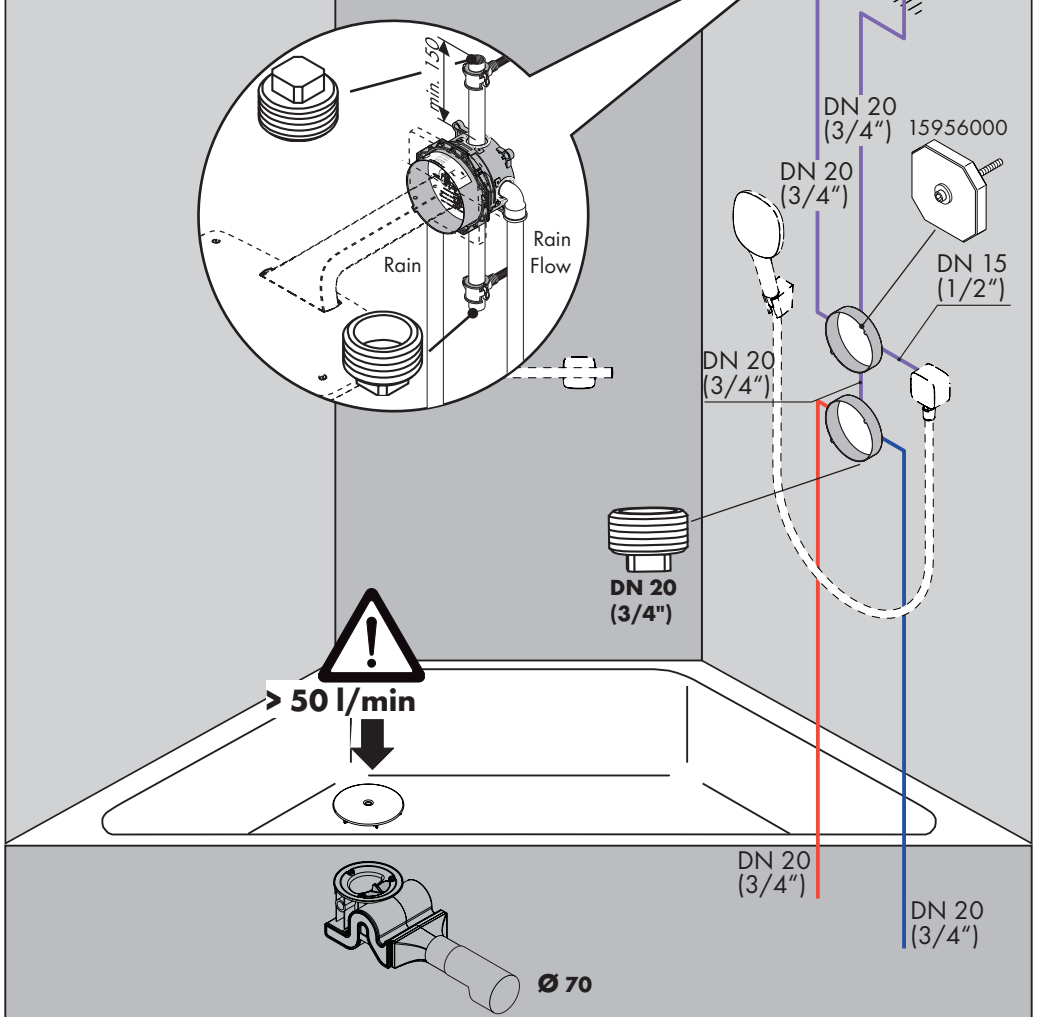
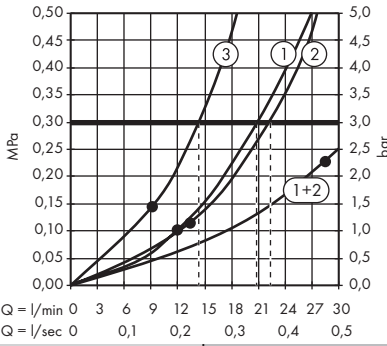
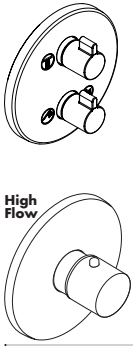





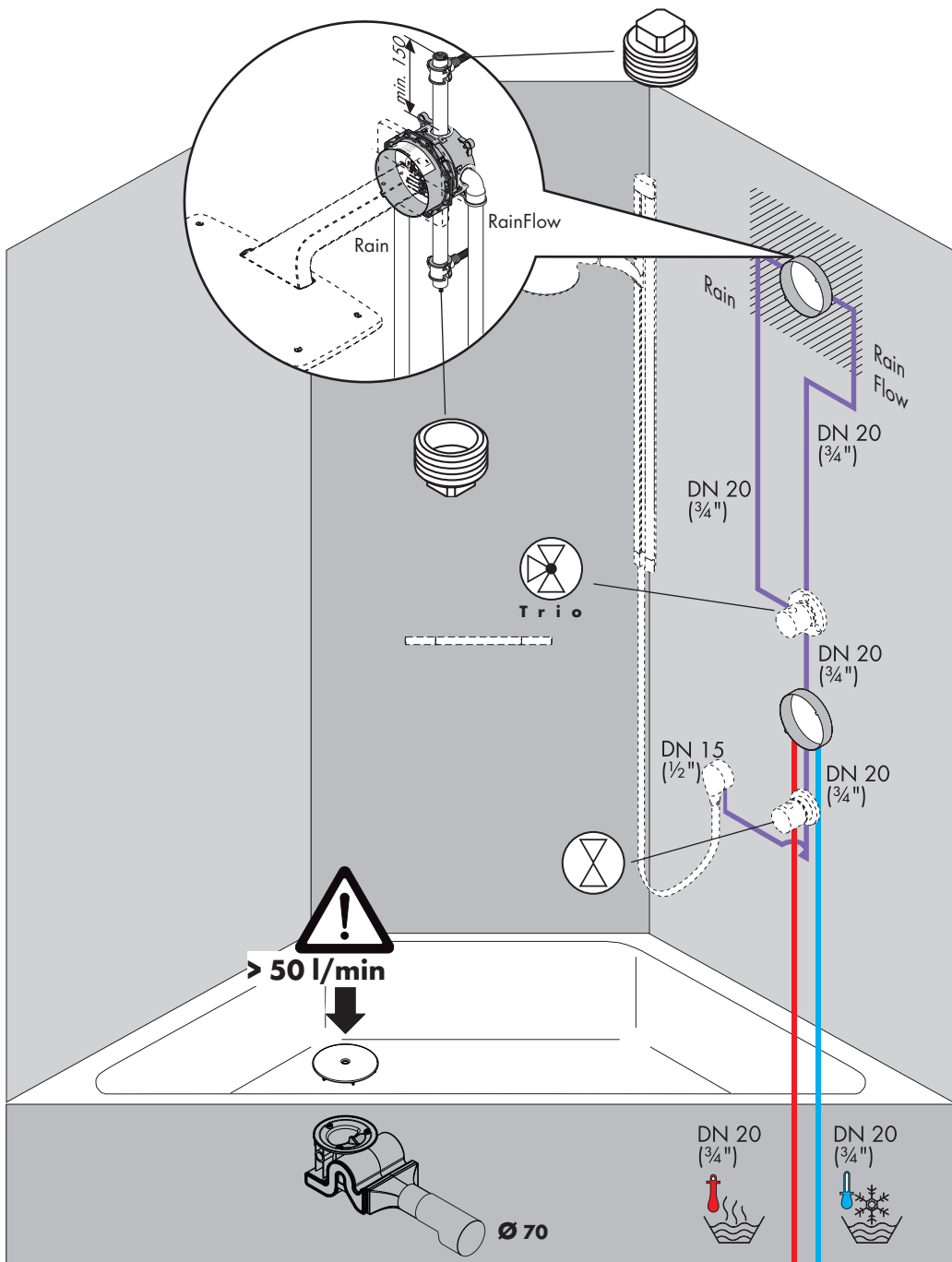

High Flow

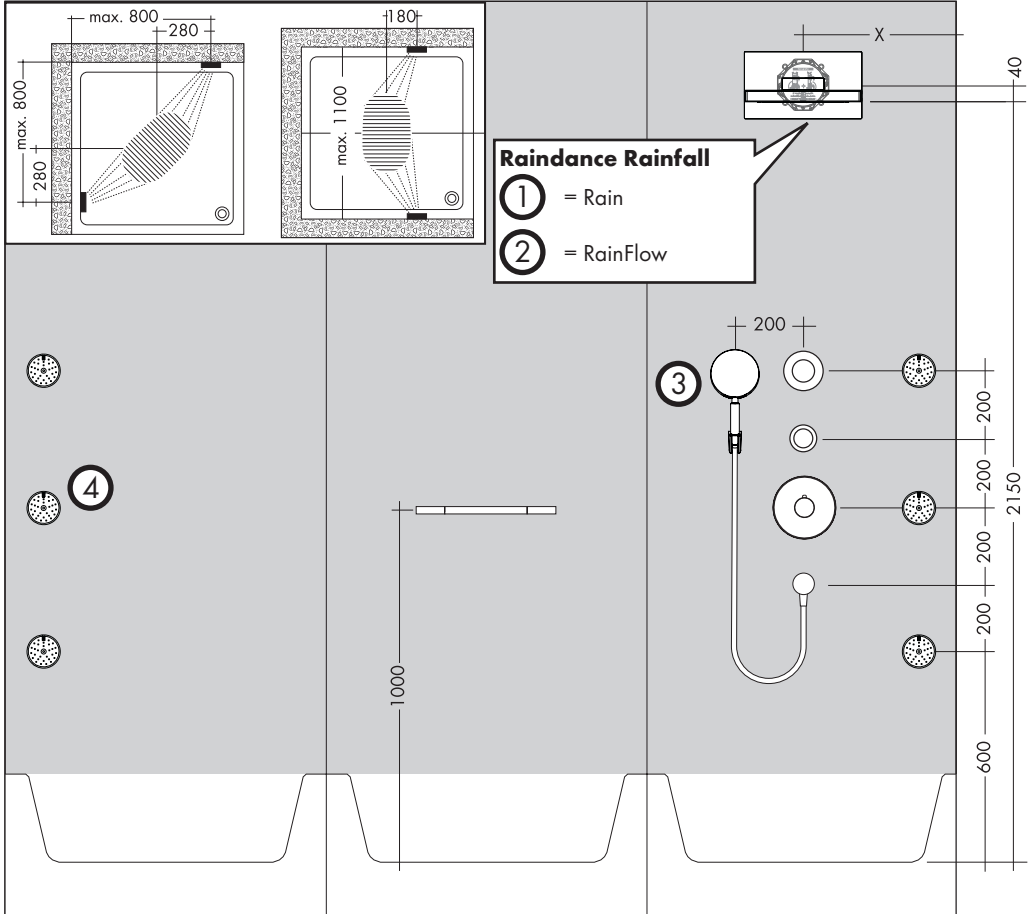
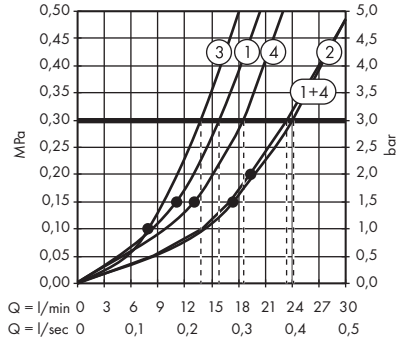
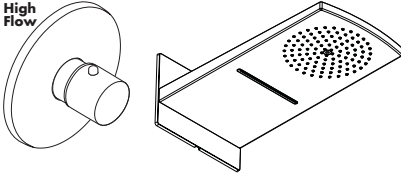

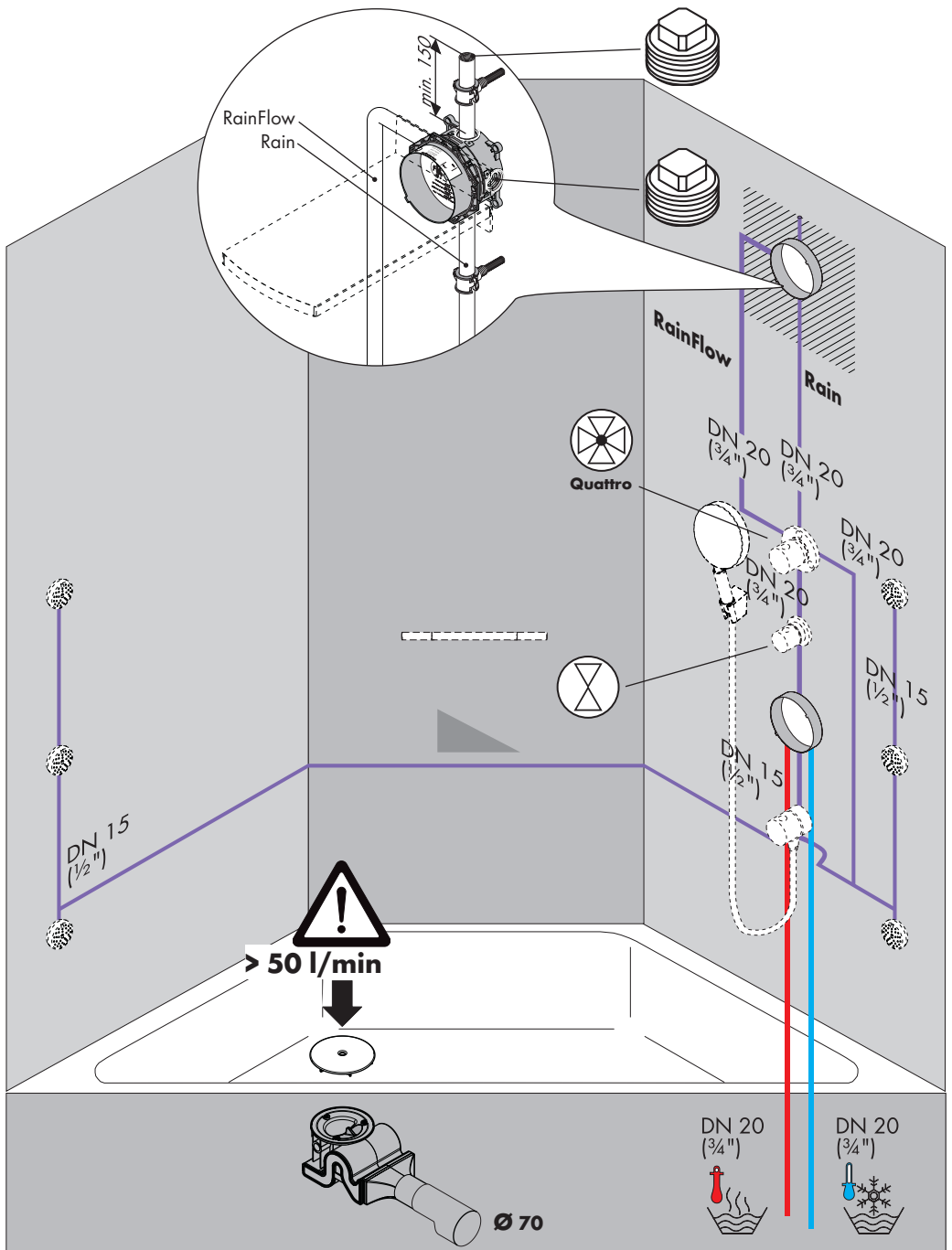

High Flow

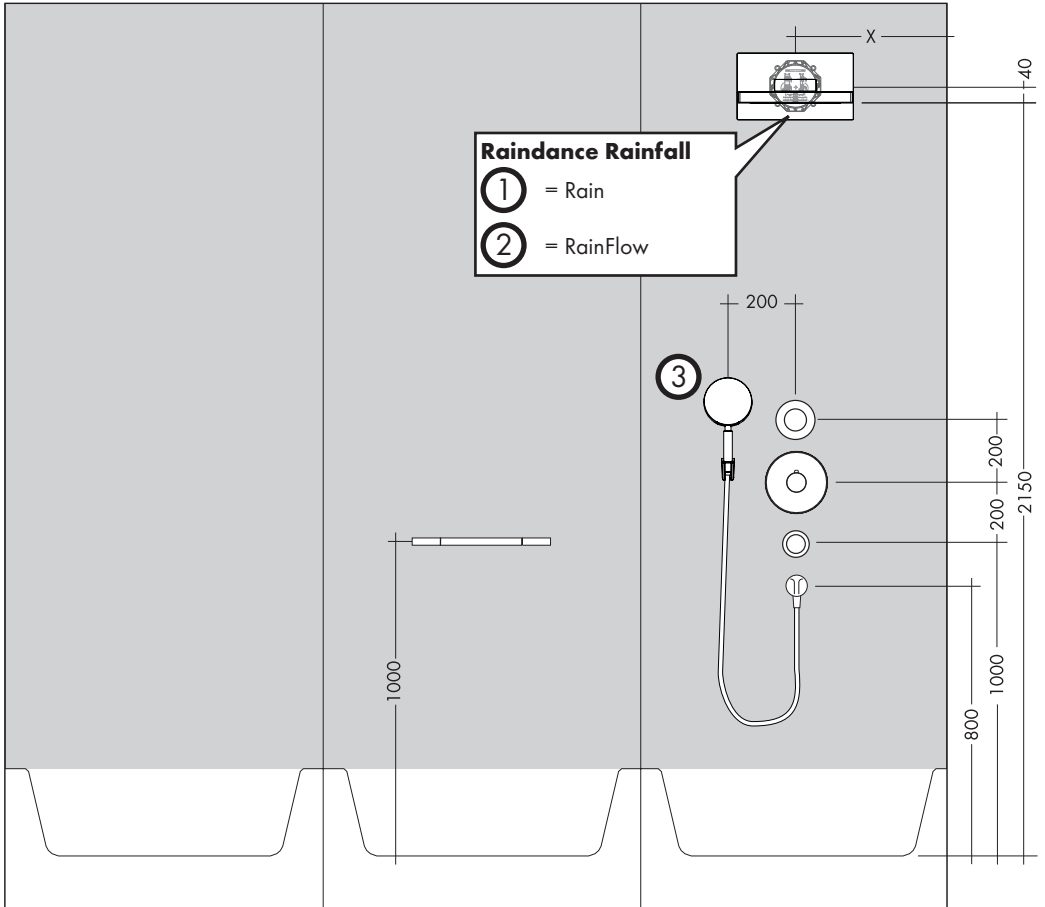
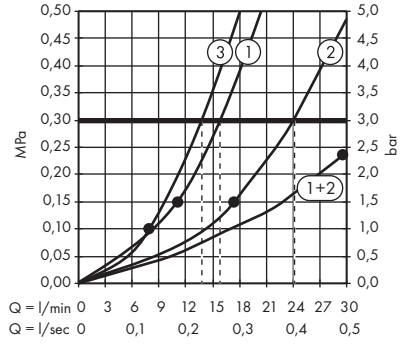
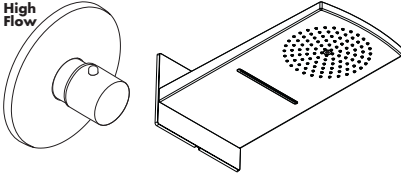

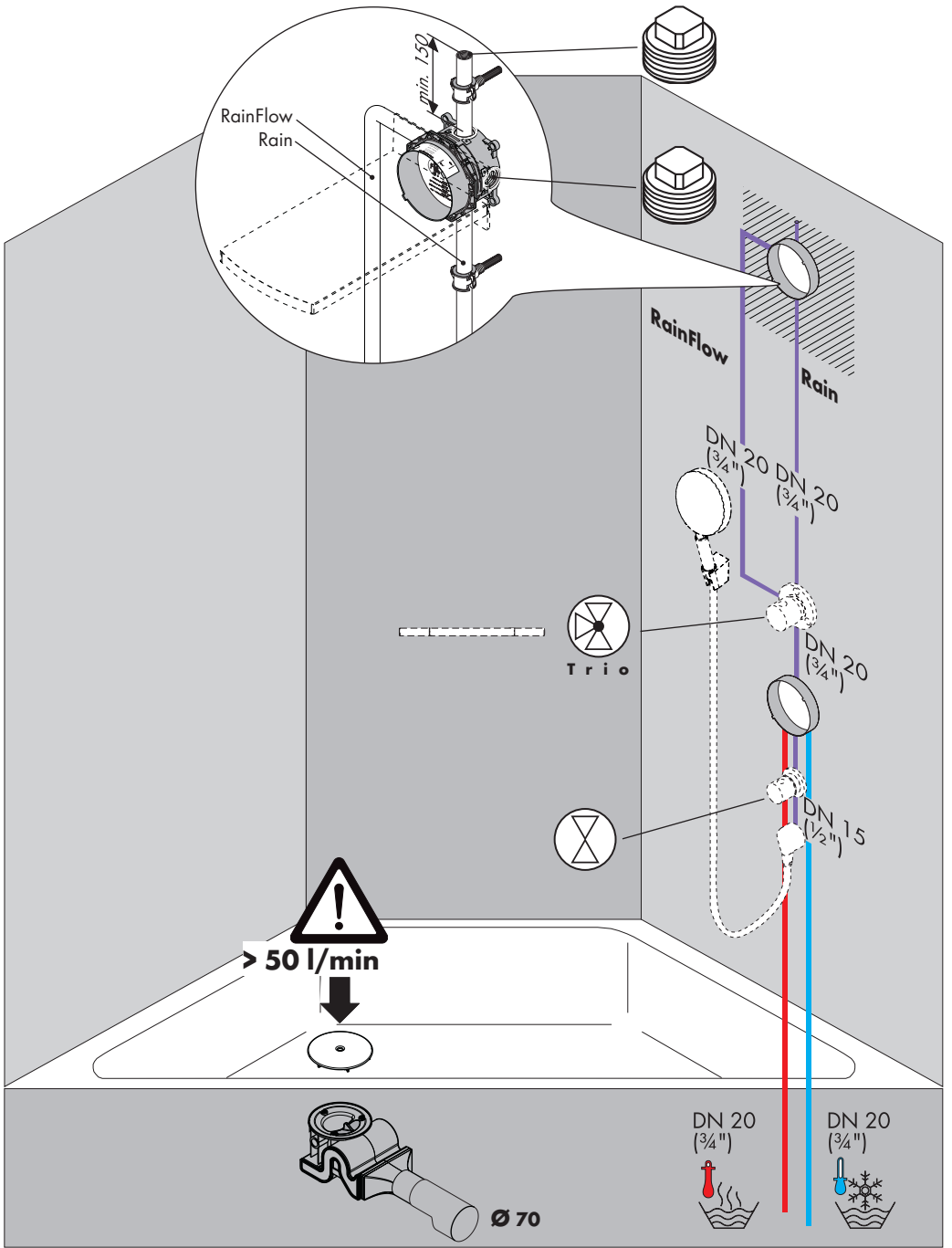

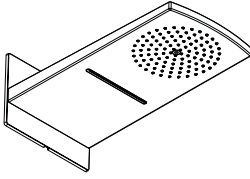
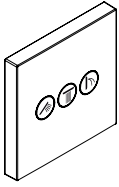

High Flow

